

EngiBOX

Product model number: UX0EMS00AM
Software: version 1.0.0R or more recent
Firmware: version 1.0.0R or more recent



User and Installation Manual

1.	Overview	4
2.	Installation	6
2.1	Mechanical installation	6
2.2	Connections & wiring	8
3.	Initialization and First Use	11
3.1	Initialization procedure	11
3.2	First Use	12
4.	How to operate the unit	13
4.1	EngiBOX Data views	13
4.2	Graphs	16
5.	Menu	18
5.1	Settings	18
5.2	Alarms	19
5.3	Export Data	19
5.4	About	19
6.	Software update	20
7.	EngiBOX App	21
7.1	App installation	21
7.2	Download data for instant support	21
8.	Technical Specifications	22
Appendix: Engine warning and alarm limits		23

DISCLAIMER & WARNINGS

The information displayed by the EngiBOX is not certified for use for VFR or IFR flights.

The EngiBOX is meant as an aid to VFR flight and is not a substitute for certified instruments.

All critical information is presented for reference only and must be verified by the user.

The EngiBOX is not a substitute for on-board instruments.

The pilot in command assumes total responsibility and risk associated with the use of this device and remains solely responsible for flying in safe conditions. AvMap disclaims any liability deriving from an improper use of the device, in a way that may violate the flight and navigation rules, regulations and safety.

1. Overview

EngiBOX is an Engine Monitoring System (EMS), developed especially for Rotax Engines, displaying the engine parameters with an update rate of five times per second and recording 160 hours of data in the internal memory. It is a rugged and reliable system designed for fixed panel installation.

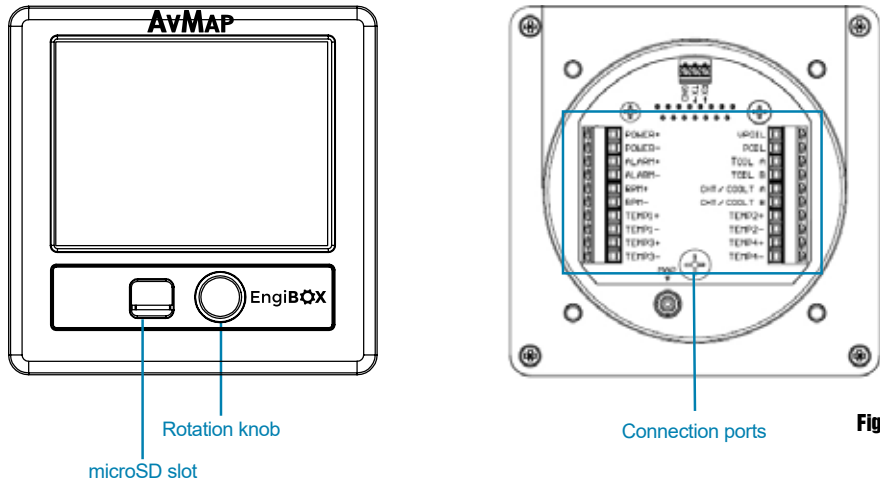

Figure 1

Note: For connection specifications see Chapter 2.

microSD card

A microSD card is provided together with the Engibox. The microSD card is a blank card without data preloaded. The microSD card should be used for software updates and export logged data from the EngiBOX to the microSD card.

Note: For more details see Chapter 4.

Rotation knob

Pressing the rotation knob allows to confirm a selection, while rotating the knob allows to change selection.

EngiBOX has 10 input ports and 1 alarm output:

- 4 x Thermocouples sensor
- 2 x PT100 sensor
- 1 x 4-20 mA pressure sensor
- 1 x RPM
- 1 x Manifold pressure sensor
- 1 x RS-232 Serial connection

- Alarm out

Note: Software 1.0.0R does not support serial connection and alarm out.

Compatible Engines

- 2 stroke Air cooled: Rotax 447 UL SCIDI, Rotax 503 UL DCIDI
- 2 Stroke Liquid cooled: Rotax 582 UL DCIDI, Rotax 618 UL DCIDI
- 4 Stroke Liquid cooled: Rotax 912 DCIDI series, Rotax 912S DCIDI series, Rotax 914 DCIDI series

EngiBOX displays:

- Exhaust Gas Temperature (EGT)
- Revolutions Per Minute (RPM)
- Manifold Pressure (MAP)
- Oil Pressure (OIL P)
- Oil Temperature (OIL T) / Air Temperature (AIR T)
- Cylinder Head Temperature (CHT) / Coolant Temperature (CT)

EngiBOX measures the engine parameters to warn you instantly if any measurement exceeds the engine limits and registers instantly the data on the internal memory. The registered data can be either exported to the micro SD card provided along with the product or send to your smartphone through the EngiBOX mobile app. In this way, data can be shared with the engine service center to receive instant support.

Further EngiBOX features:

- Wizard to initialize the engine,
- Parameters displayed in two alternative views: graphic or numeric,
- Graph page to analyze the performance per each engine parameter (last 20 minutes),
- Clock page to show flight time, engine lifetime and time since last overhaul.

Note: Engine initialization may not be needed in case unit installation has been already performed by the engine service center or the aircraft manufacturer.

2. Installation

The installation procedure is divided in the following steps:

- Mechanical installation
- Connections & wiring

2.1 Mechanical installation

EngiBOX is designed to be installed on the aircrafts instrument panel, in a standard 3 1/8" (79,5 mm) diameter hole. Make sure you have enough space on the front and behind the cockpit panel to install the EngiBOX.

Check the EngiBOX main dimensions reported in Figure 2.

The instrument has to be installed from the front of the panel and screwed from behind the panel according to Figure 3.

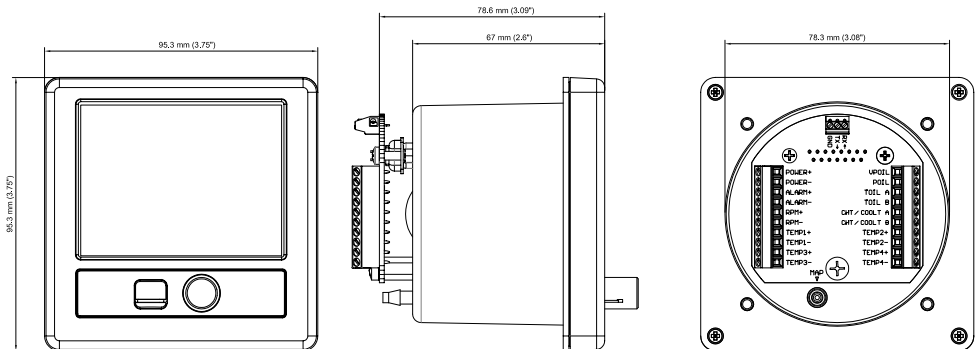

Figure 2

The screw length that need to be used for panel installation depend on the panel thickness and is based on the following formula:

$$5\text{mm} \leq l - t \leq 8\text{mm}$$

l = length of the screw

t = thickness of the panel

Use the screws and metal washer included in the box for standard panel thickness of up to 3mm. For thicker instrument panels, use longer screws and use the formula to choose the right screw length.

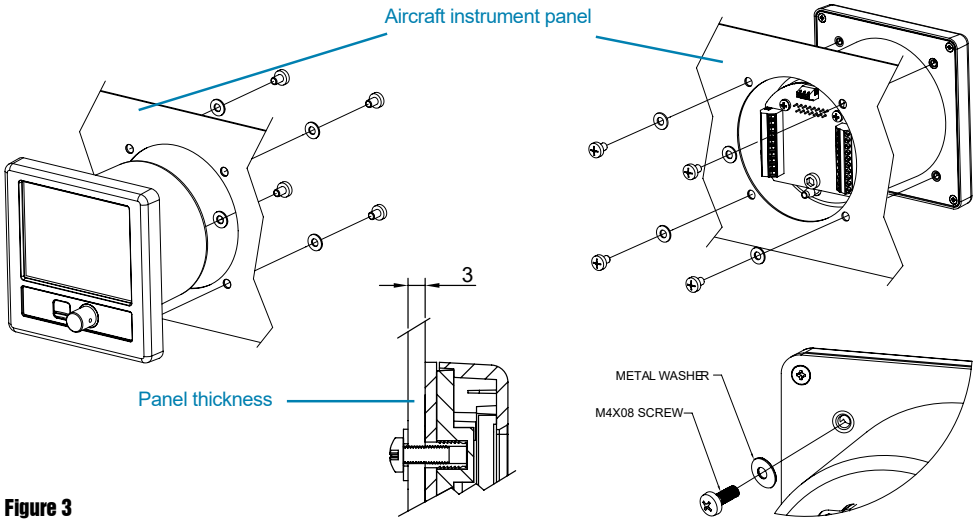

Figure 3

IMPORTANT: Make sure you respect the screw length formula to avoid damaging the plastic of the EngiBOX. Use light thread locker to prevent screw loosening with vibration. Use the cutting template, included in the box, to cut out the panel. (see Figure 4)

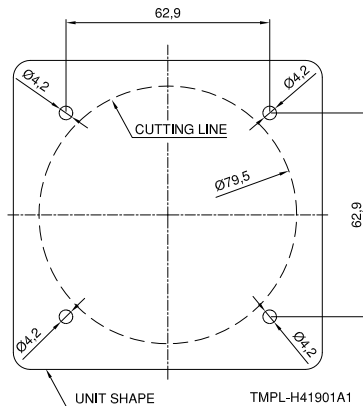

Figure 4

2.2 Connections & wiring

EngiBOX has several sensor input ports, which can be occupied variably according to the connected engine type. On the back of the EngiBOX there are several connections, see Figure 5.

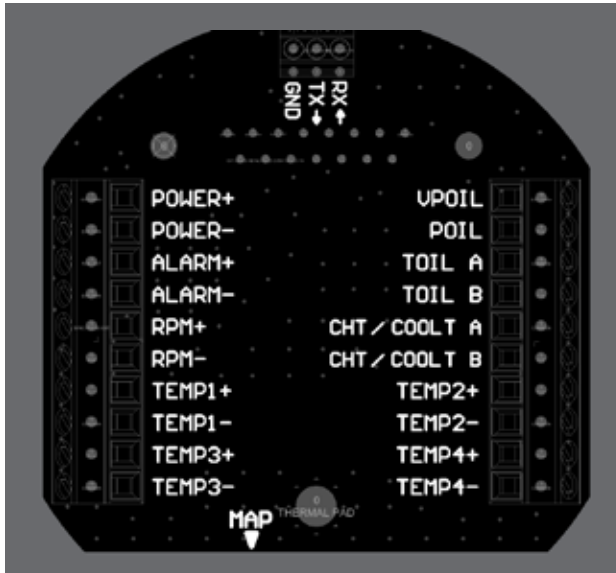

Figure 5

Note: See Table 1 or 2 for the connection specification relative to your engine type.

4 Stroke Engines

Table 1

LEFT			RIGHT
external power positive input	POWER +	VPOIL	oil pressure sensor alimentation at external power voltage
external power negative input	POWER -	POIL	oil pressure sensor input
output at external power voltage + (disabled)	ALARM +	TOIL A	oil temperature input A
output at external power voltage -	ALARM -	TOIL B	oil temperature input B
RPM positive input	RPM +	CHT / COOLT A	CHT or CT input A
RPM negative input	RPM -	CHT / COOLT B	CHT or CT input B
EGT PTO R +	TEMP1 +	TEMP2 +	EGT PTO L +
EGT PTO R -	TEMP1 -	TEMP2 -	EGT PTO L -
EGT MAG R +	TEMP3 +	TEMP4 +	EGT MAG L +
EGT MAG R -	TEMP3 -	TEMP4 -	EGT MAG L -

2 Stroke Engines

Table 2

LEFT	RIGHT		
external power positive input	POWER +	VPOIL	NOT USED
external power negative input	POWER -	POIL	NOT USED
output at external power voltage + (disabled)	ALARM +	TOIL A	CT input A
output at external power voltage -	ALARM -	TOIL B	CT input B
RPM positive input	RPM +	CHT / COOLT A	air temperature input A
RPM negative input	RPM -	CHT / COOLT B	air temperature input B
EGT PTO +	TEMP1 +	TEMP2 +	CHT PTO +
EGT PTO -	TEMP1 -	TEMP2 -	CHT PTO -
EGT MAG +	TEMP3 +	TEMP4 +	CHT MAG +
EGT MAG -	TEMP3 -	TEMP4 -	CHT MAG -

Note: PTO stands for power take off side and MAG for magneto side of the engine.

EngiBOX is compatible with the following sensors:

Sensors	
4 x INPUT Thermocouple (type K)	
Application:	Exhaust Gas Temperature (EGT) (2 Stroke / 4 Stroke) Cylinder Head Temperature (CHT) (2 Stroke)
2 x INPUT Thermoresistance (PT-100)	
Application:	Air Temperature, Coolant Temperature (2 Stroke) Oil Temperature, Cylinder Head Temperature / Coolant Temperature (4 Stroke)
1 x INPUT Oil Pressure pick-up (4-20 mA Rotax 456-180 or equivalent)	
Measuring range:	0.75 to 10.75 bar
Application:	Oil Pressure (4 Stroke)
1 x RPM pick-up	
Measuring range:	100 to 9990 rpm
1 x INPUT Manifold Pressure	
Measuring range:	200 to 2500 hPa

Note: Thermocouple and Manifold pressure input can be used in parallel with other measurement devices.

WARNING: Thermocouple, PT-100 and Oil pressure sensors must not be referred to GND or negative external power.

Power supply

Power the EngiBOX from an 10 to 35 Vdc supply. Mount on the power wire (RED) the 1A fuse holder, provided in the box, to protect against short circuits.

Serial Connection

The EngiBOX has serial RS232 connection ports to interface to an external device.

Note: current software 1.0.0R does not support serial in/out interface.

Wires lock system

Use the wire lock system, provided together with the EngiBOX, to tighten all wires together that are connected to the EngiBOX (see Figure 6).

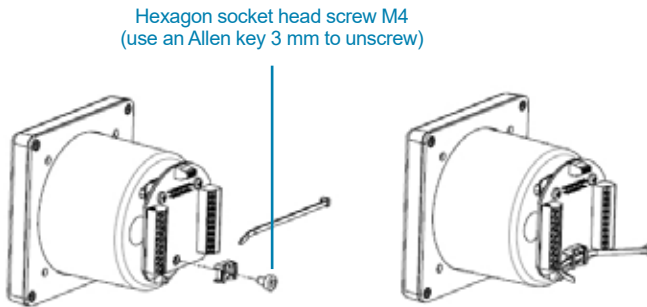

Figure 6

WARNING: At installation of the sensors take into consideration the following:

- Route sensor lines to be protected against excessive temperatures.
- Route sensor lines free of vibrations, but with some flexibility.
- Sensor lines to be without kinks and must not chafe.
- The threads of the thermocouple sensors and pick-up of PT-100 sensors have to be greased with Loctite ANTI-SEIZE, to ensure trouble free removal.
- Shortcomings in these points can result in false readings, interruption of lines or the ruin of pick-up lines and sensors.

Note: Usually, the sensors are furnished by the supplier with pickup lines of 2 m (6' - 6") length, but can be extended to a max. length of 4 m (13').

- Thermocouples (type K) to be extended with compatible resistor cables only. Connections have to be soldered and insulated, preferably by shrink tube.
- Never establish connections by clamping, danger of false reading due to higher contact resistance. Thermocouple compatible resistor cables are available in a specialist store or from your local Rotax Service Center.
- All other sensors can be extended by suitable stranded copper wire.

ATTENTION: Always bear in mind, you are dealing with measuring devices when you install sensors, and handle these sensitive components carefully.

AvMap declines any responsibility of the connections to the engine. AvMap strongly advise to follow the instructions of the Rotax engine manual and the installation to be performed by a qualified Rotax service center. For any question, please contact your local Rotax Service Center.

3. Initialization and First Use

3.1 Initialization procedure

The engine initialization procedure is necessary to pair EngiBOX to the connected engine model.

Note: Engine initialization may not be needed in case unit installation has been already performed by the engine service centre or the aircraft manufacturer.

When you connect EngiBOX to the power for the first time, you will see the Initialization message. Follow the wizard, pressing the knob to start the initialization according to these steps:

1. Enter date and time
 - Press the knob to open the controller
 - Rotate the knob to choose the value
 - Press the knob again to close the controller
 - Finally, press the knob to confirm and proceed
2. Select the engine type
 - Rotate the knob to select your engine type and press the knob to confirm.
 - EngiBOX asks you for confirmation, press again OK to proceed.
3. Enter the engine ID
 - Rotate the knob to select the character and press to confirm.
 - Select OK and press the knob to proceed
4. The recap page shows all the entered data
 - Press the knob to confirm, or select cancel to start again from the beginning.

Note: After this step the initialization is completed. The device is operating in test mode and data will not be registered till next power on.

IMPORTANT: After initialization confirmation the EngiBOX is programmed for the selected engine model and engine ID. Only authorized service centres and AvMap Support can reprogram the EngiBOX and restart the initialization procedure.

5. Bluetooth Test

Next step is the Bluetooth test. For this test you need your Smartphone/Tablet (with Bluetooth 4.0), where you have already downloaded the EngiBOX app (that you can get for free from the App Store).

- Choose Skip or OK and press the knob to confirm.
- Activate the Bluetooth on your Smartphone / tablet.
- Launch the EngiBOX app. The app will scan for EngiBOX in the surroundings and the list of found devices will appear in the left column.
- Select your EngiBOX according to the EngiBOX ID.

Note: Follow instructions reported in paragraph 5.4 to read the EngiBOX ID

- Follow the wizard to register your EngiBOX (needed just the first time).
- Power off the unit.

3.2 First Use

The first time you power on the EngiBOX after the initialization, you need to enter all the settings.

1. Language:

- Rotate the knob to choose the desired language
- Press the knob to tick the checkbox
- Press the knob to confirm and proceed

2. Units:

Set the desired unit of measure for pressure (Bar, Kg/cm², Psi), manifold pressure (Hpa, inHg) and temperature (C°, F°).

- Press the knob to open the controller
- Rotate the knob to choose the desired unit of measure
- Press the knob again to confirm and proceed

3. Date and time:

- Rotate the knob to select month, day, year, hours, minutes and seconds
- Press the knob to open the controller
- Rotate the knob to choose the value
- Press the knob again to close the controller
- Finally, press the knob to confirm and proceed

4. Warning page:

- Read the warning
- Select OK and press the knob to confirm and proceed
- EngiBOX is ready to be used

4. How to operate the unit

EMS data – view 1: data are displayed highlighting graphically engine trends, warning and alarm limits.

EMS data – view 2: data are displayed highlighting the values of engine trends, warning and alarm limits.

Graph Pages: graphs available for performance analysis of the last 20 minutes for each engine parameter.

Clock Page: includes flight time, total lifetime and time since the last overhaul.



4.1 EngiBOX Data views

According to your engine model you will be able to monitor different data:

Rotax 912 series, Rotax 912S series and Rotax 914 series

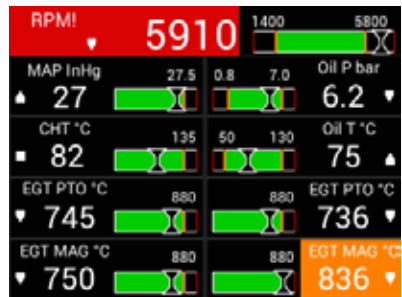

- Revolutions per Minute (RPM)
- Manifold Pressure (MAP)
- Oil Pressure (Oil P)
- Oil Temperature (Oil T)
- Cylinder Head Temperature (CHT) / Coolant Temperature (CT)
- Exhaust Gas Temperature (EGT), PTO left and right
- Exhaust Gas Temperature (EGT), MAG left and right

Rotax 447 UL, Rotax 503 UL and Rotax 618 UL

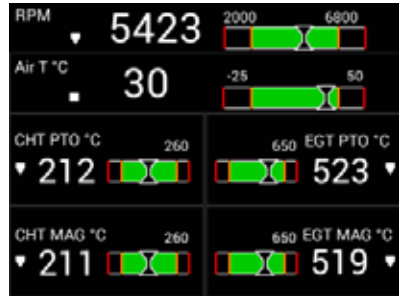
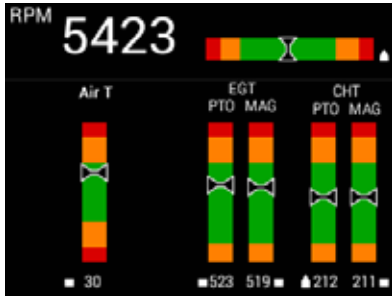

- Revolutions per Minute (RPM)
- Air Temperature (Air T)
- Exhaust Gas Temperature (EGT), PTO
- Exhaust Gas Temperature (EGT), MAG
- Cylinder Head Temperature (CHT), MAG
- Cylinder Head Temperature (CHT), PTO

Rotax 582 UL

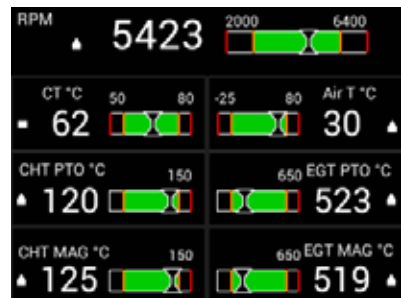
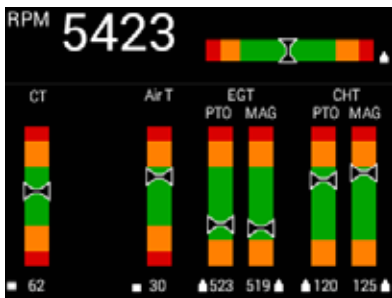

- Revolutions per Minute (RPM)
- Coolant Temperature (CT)
- Air Temperature (Air T)
- Exhaust Gas Temperature (EGT), PTO
- Exhaust Gas Temperature (EGT), MAG
- Cylinder Head Temperature (CHT), PTO
- Cylinder Head Temperature (CHT), MAG

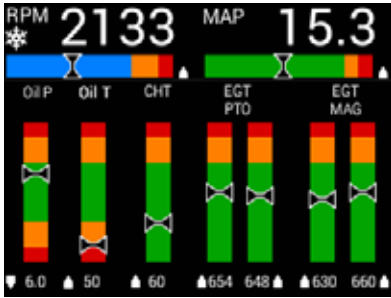

4.1.1 EMS data – View 1

In the first data page the engine trends, warning and alarm limits are highlighted graphically. Each parameter is shown with 3 elements: the pointer in a coloured bar, the numeric value, the trend icon.

Coloured bar legend:

- Blue (only for RPM bar) is shown when the engine is yet too cold for take off. Once the right oil temperature is reached, the RPM bar turns green.

- Green area: normal operation
- Yellow area: warning limit
- Red area: exceeding alarm limit

Note: see Appendix “Engine warning and alarm limits” to know the values for your engine.

Trend icon legend:

- Arrow up: the value is increasing
- Arrow down: the value is decreasing
- Square: the value is stable

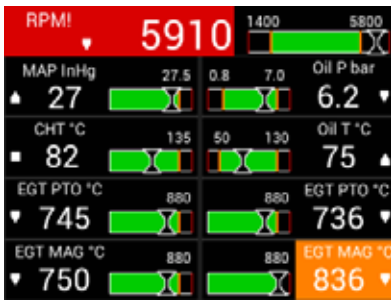

4.1.2 EMS data – View 2:

The second data page highlights values. Each parameter is shown with 4 elements: the pointer in the coloured bar, the numeric value, numeric alarm limit, the trend icon.

Coloured bar legend:

- Black area: below or above the warning and alarm limits
- Green area: normal range of values
- Yellow line: warning limit
- Red line: exceeding alarm limit. The alarm limit value is shown in white above the black area.

Trend icon legend:

- Arrow up: the value is increasing
- Arrow down: the value is decreasing
- Square: the value is stable

4.1.3 Alarms

Warning limit: the black background for each value turns yellow when the parameter is approaching the warning limit.

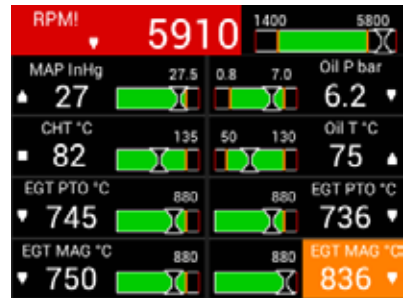
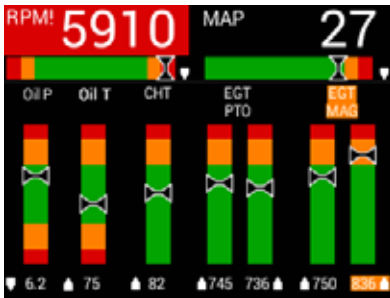

Alarm limit: the black background for each value turns red when the alarm limit is exceeded.

Alarm Reminder ! : Once an alarm has been activated, an exclamation mark appears next to the parameter abbreviation and remains there even when the parameter goes back to the normal value.

This mark is a useful reminder, in fact, in case you have not noticed the alarm, you can always see the exclamation mark at the end of your flight next to the parameter abbreviation. Go to Settings and open the Alarms page to check date and time of the alarm activation (Chapter 5). The exclamation mark will remain on the display till you clear the alarms in the Alarms page.

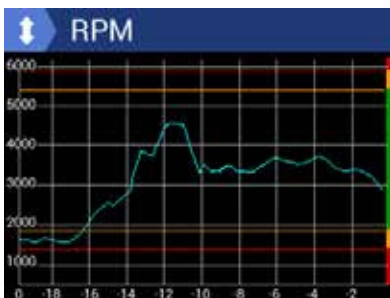

4.2 Graphs

Graphs are available for performance analysis of the last 20 minutes for each engine parameter.

To change parameter, press the knob: the arrow icon in the top left corner becomes orange, and you can now rotate the knob to cycle among the parameter.

Press again the knob to go back and continue cycling among the pages.

15:34	
Flight time	03h:32''
Time since overhaul	323h:45''
Total lifetime	602h:23''
03-18-2015	

4.3 Clock page

The clock page includes time, flight time, total lifetime, time since the last overhaul and date. The EngiBOX will ask you monthly to check and confirm the time.

5. Menu

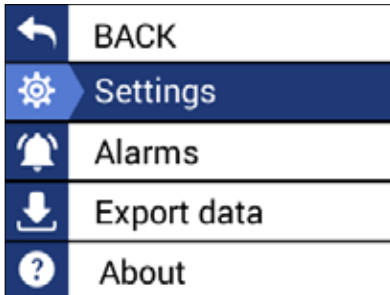

To access the Menu press and hold the knob for 5 seconds, the Menu page will appear. To go back to the main pages, press again for 5 seconds, or wait: the Menu page will be closed automatically after 10 seconds of inactivity. Rotate the knob to select a menu item and press to confirm: Settings, Alarms, Export data and About.

5.1 Settings

In the settings page you can set up brightness, language, Bluetooth, units of measure, date and time; and you can perform a Factory Settings Reset.

5.1.1 Brightness:

- Rotate the knob to select Brightness
- Press the knob to open the brightness controller
- Rotate the knob to choose the desired display brightness
- Press the knob again to close the brightness controller
- Rotate the knob to choose BACK and press to confirm and exit

5.1.2 Language:

- Rotate the knob to choose the desired language
- Press the knob to tick the checkbox
- Rotate the knob to choose BACK and press to confirm and exit

5.1.3 Bluetooth:

- Rotate the knob to choose Activate
- Press the knob to tick the checkbox
- Rotate the knob to choose BACK and press to confirm and exit

5.1.4 Units:

Set here the desired unit of measure for pressure (Bar, Kg/cm², Psi), manifold pressure (Hpa, inHg) and temperature (C°, F°).

- Rotate the knob to choose the desired unit
- Press the knob to tick the checkbox
- Rotate the knob to choose the unit of measure and press the knob to confirm
- Rotate the knob to choose BACK and press to confirm and exit

5.1.5 Date and time:

- Rotate the knob to select month day, year, hours, minutes and seconds
- Press the knob to open the controller
- Rotate the knob to choose the value
- Press the knob again to close the controller
- Rotate the knob to choose BACK and press to confirm and exit

5.1.6 Settings Reset:

- You will be asked for confirmation
- Select OK and Press the knob to confirm

5.2 Alarms:

You can find here the recap of the alarms that have been activated with: status, value, date and time. Once you have read the alarm, press clear to remove the exclamation mark from the data view pages. Rotate the knob to select OK and press to confirm.

5.3 Export Data

Engine parameters are monitored with an update rate of five times per second. Data are recorded and stored in the internal memory up to 160 hours.

In order to download the data log you can use:

- The EngiBOX mobile app for iOS and Android (see chapter 7)
- The microSD card (insert the microSD card into the EngiBOX and choose Export Data to export the stored data from the device on the microSD card)

5.4 About

You can read here: the EngiBOX ID, Boot version, Loader version, Software version, Engine type, Total lifetime of the engine and Time since last overhaul. Rotate the knob to choose BACK and press to exit.

IMPORTANT: the EngiBOX ID is needed to register your EngiBOX through the EngiBOX APP, in order to download data and get customer support.

6. Software update

Software updates are released by AvMap for free. You just need to register your EngiBOX at <http://www.avmap.it/support/Registration>. Registration is needed to get Customer Support.

1. Visit <http://www.avmap.it/support/download>, choose Select > Aeronautical products > Instruments > EngiBOX to find out if there is a software update for your EngiBOX.
2. Click on Download. (You need to be registered on the AvMap website) if you are not logged in, you can insert your login and Password received at the moment of registration.
3. Copy the software file on the microSD card.
4. Insert the microSD card into the EngiBOX while the EngiBOX is turned OFF.
5. Turn the EngiBOX ON providing power to the device. Automatically the EngiBOX starts the update procedure. At the end of the update procedure the devices asks to press the knob to proceed.
6. After the update process the EngiBOX starts up. You can check the software version in the About page (see paragraph 5.4).

7. EngiBOX App



You can download the EngiBOX mobile app (iOS and Android) for free on your Smartphone / tablet.

7.1 App installation

1. Activate the Bluetooth on your Smartphone / tablet
2. Launch the EngiBOX app. The app will scan for EngiBOX in the surroundings and the list of found devices will appear in the left column.
3. Select your EngiBOX according to the EngiBOX ID.
4. In case of first use, follow the wizard to register your EngiBOX.

7.2 Download data for instant support

1. Launch the EngiBOX mobile app.
2. Select your EngiBOX from the left column to connect to it.
3. The app shows: EngiBOX ID, connection status. Engine model, Engine ID number and date of last overhaul. In order to download available data touch DOWNLOAD DATA.
4. Choose how many minutes you want to download: the minimum is the last 30 minutes of activity, the maximum 10 hours and 30 minutes (see the estimated time for download in the bottom right corner)
5. When the download is complete, press the SEND icon. The service center will receive all your engine logs.

Once the operation is completed, contact the service center communicating your engine ID to get Instant Support Service.

8. Technical Specifications

Hardware:

- Dimensions: 95 x 95 x 88 mm
- Fitting standard 3-1/8" (79.5 mm) panel hole
- Weight: 250 g
- Display: 3.5" colour LCD, with anti reflective coat, 320x240 pixels, 500 cm/m2
- MicroSD slot
- Real Time Clock
- DB15 connector with antivibration lock system:
 - 4 x Thermocouple sensor
 - 2 x PT100 sensor
 - 1 x 4-20 mA pressure sensor
 - 1 x RPM
 - 1 x Serial connection
- Manifold pressure sensor
- Bluetooth Low Energy
- Power Input range: 10-35 VDC
- Current consumption @ 12VDC: 150 mA MAX
- Operating Temperature range: -20° C / +70° C

Software:

- Wizard driven engine initialization
- Engine data displayed in two alternative views
- Graph page for each engine parameter
- Clock page including flight time, total lifetime, time since overhaul
- Data registration on internal memory and data export to micro SD or EngiBOX mobile App

Included accessories:

- Mounting KIT (Cutting template, 4x metal washers and 4x screws)
- Wires lock system
- 1x 1A fuse holder
- Blank microSD card
- Microfiber cleaner cloth

Appendix: Engine warning and alarm limits

4 Stroke Engines (912/912S DCDI Series)

Engine Model: 912 DCDI Series*, with Coolant Temperature (CT)						
Limits	EGT PTO - EGT MAG (°C)	OIL T (°C)	CT (°C)	OIL P (bar)	MAP (InHg)	RPM
Min	0	0	0	0	0	0
Alarm low	0	50	0	1,5	0	1400
Warning low	0	55	0	1,8	0	1700
Warning high	840	130	110	5	27	5500
Alarm high	880	140	120	7	27,5	5800
Max	900	150	150	8	30	6000
*912 UL / 912 A / 912 F						
Note: Cold engine: When oil temperature is under warning low limit, RPM must be under 3500						

Engine Model: 912 DCDI Series*, with Cylinder Head Temperature (CHT)						
Limits	EGT PTO - EGT MAG (°C)	OIL T (°C)	CHT (°C)	OIL P (bar)	MAP (InHg)	RPM
Min	0	0	0	0	0	0
Alarm low	0	50	0	1,5	0	1400
Warning low	0	55	0	1,8	0	1700
Warning high	840	130	140	5	27	5500
Alarm high	880	140	150	7	27,5	5800
Max	900	150	160	8	30	6000
*912 UL / 912 A / 912 F						
Note: Cold engine: When oil temperature is under warning low limit, RPM must be under 3500						

Engine Model: 912S DCDI Series*, with Coolant Temperature (CT)						
Limits	EGT PTO - EGT MAG (°C)	OIL T (°C)	CT (°C)	OIL P (bar)	MAP (InHg)	RPM
Min	0	0	0	0	0	0
Alarm low	0	50	0	0,8	0	1400
Warning low	0	55	0	2	0	1700
Warning up	840	120	110	5	27	5500
Alarm up	880	130	120	7	27,5	5800
Max	900	140	150	8	30	6000
*912 ULS / 912 S						
Note: Cold engine: When oil temperature is under warning low limit, RPM must be under 3500						

Engine Model: 912S DCDI Series*, with Cylinder Head Temperature (CHT)						
Limits	EGT PTO - EGT MAG (°C)	OIL T (°C)	CHT (°C)	OIL P (bar)	MAP (InHg)	RPM
Min	0	0	0	0	0	0
Alarm low	0	50	0	0,8	0	1400
Warning low	0	55	0	2	0	1700
Warning up	840	120	125	5	27	5500
Alarm up	880	130	135	7	27,5	5800
Max	900	140	145	8	30	6000
*912 ULS / 912 S						
Note: Cold engine: When oil temperature is under warning low limit, RPM must be under 3500						

4 Stroke Engines (914 DCDI series)

Engine Model: 914 DCDI Series*, with Coolant Temperature (CT)						
Limits	EGT PTO - EGT MAG (°C)	OIL T (°C)	CT (°C)	OIL P (bar)	MAP (InHg)	RPM
Min	0	0	0	0	0	0
Alarm low	0	50	0	1,5	0	1400
Warning low	0	55	0	1,8	0	1700
Warning up	900	120	110	5	35,4	5500
Alarm up	950	130	120	7	39,8	5800
Max	970	140	150	8	39,9	6000
*914 UL / 914 F						
Note: Cold engine: When oil temperature is under warning low limit, RPM must be under 3500						

Engine Model: 914 DCDI Series*, with Cylinder Head Temperature (CHT)						
Limits	EGT PTO - EGT MAG (°C)	OIL T (°C)	CHT (°C)	OIL P (bar)	MAP (InHg)	RPM
Min	0	0	0	0	0	0
Alarm low	0	50	0	1,5	0	1400
Warning low	0	55	0	1,8	0	1700
Warning up	900	120	125	5	35,4	5500
Alarm up	950	130	135	7	39,8	5800
Max	970	140	145	8	39,9	6000
* 914 UL / 914 F						
Note: Cold engine: When oil temperature is under warning low limit, RPM must be under 3500						

2 Stroke Engines (447 UL SCDI, 503 UL DCDI, 582 UL DCDI, 618 UL DCDI)

Engine Model: 447 UL SCDI				
Limits	EGT PTO - EGT MAG (°C)	CHT PTO - CHT MAG (°C)	AIR T (°C)	RPM
Min	0	0	-50	0
Alarm low	0	0	-25	2000
Warning low	460	190	0	2300
Warning up	580	230	40	6500
Alarm up	650	260	50	6800
Max	680	275	60	7000
Note: Cold engine: When Cylinder Head Temperature is under warning low limit, RPM must be under 2500				

Engine Model: 503 UL DCDI				
Limits	EGT PTO - EGT MAG (°C)	CHT PTO - CHT MAG (°C)	AIR T (°C)	RPM
Min	0	0	-50	0
Alarm low	0	0	-25	2000
Warning low	460	180	0	2300
Warning up	580	220	40	6500
Alarm up	650	250	50	6800
Max	680	275	60	7000
Note: Cold engine: When Cylinder Head Temperature is under warning low limit, RPM must be under 2500				

Engine Model: 582 UL DCDI					
Limits	EGT PTO - EGT MAG (°C)	CHT PTO - CHT MAG (°C)	CT (°C)	AIR T (°C)	RPM
Min	0	0	0	-50	0
Alarm low	0	0	50	-25	2000
Warning low	500	110	55	0	2300
Warning up	620	130	75	40	6000
Alarm up	650	150	80	50	6400
Max	680	180	95	60	7000
Note: Cold engine: When Coolant Temperature is under warning low limit, RPM must be under 2500					

Engine Model: 618 UL DCDI				
Limits	EGT PTO - EGT MAG (°C)	CHT PTO - CHT MAG (°C)	AIR T (°C)	RPM
Min	0	0	-50	0
Alarm low	0	0	-25	2000
Warning low	500	110	0	2300
Warning up	620	130	40	6900
Alarm up	650	150	50	7000
Max	680	180	60	7300
Note: Cold engine: When Cylinder Head Temperature is under warning low limit, RPM must be under 2500				

EngiBOX

AVMAP
SATELLITE NAVIGATION

www.avmap.it
www.avmap.us
www.avmap.com.br

MAEMSAM0AE020

