

**ROTAX®**

# OPERATORS MANUAL

**FOR ROTAX ENGINE TYPES 914 SERIES**

REF NO.: OM-914 | PART NO.: 899706



 **WARNING**

**Before starting the engine, read the Operators Manual, as it contains important safety relevant information. Failure to do so may result in personal injuries including death. Consult the original equipment manufacturer's handbook for additional instructions!**

These technical data and the information embodied therein are the property of BRP-Rotax GmbH & CO KG, Austria, acc, BGBl 1984 no. 448, and shall not, without prior written permission of BRP-Rotax GmbH & Co KG, be disclosed in whole or in part to third parties. This legend shall be included on any reproduction of these data, in whole or in part. The Manual must remain with the engine/aircraft in case of sale.

ROTAX<sup>®</sup> is a trade mark of BRP-Rotax GmbH & Co KG. In the following document the short form of BRP-Rotax GmbH & Co KG = BRP-Rotax is used. Other product names in this documentation are used purely for ease of identification and may be trademarks of the respective company or owner.

Copyright 2019 © - all rights reserved.

Translation into other languages might be performed in the course of language localization but does not lie within ROTAX<sup>®</sup> scope of responsibility.

In any case the original text in English language and the metric units are authoritative.

# Table of Content

<b>Chapter</b>	<b>INTRO</b> – Introduction
<b>Chapter</b>	<b>LEP</b> – LIST OF EFFECTIVE PAGES
<b>Chapter</b>	<b>TOA</b> – Table of amendments
<b>Chapter</b>	<b>1</b> – General note
<b>Chapter</b>	<b>2</b> – Operating instructions
<b>Chapter</b>	<b>3</b> – Standard operation
<b>Chapter</b>	<b>4</b> – Abnormal operation
<b>Chapter</b>	<b>5</b> – Performance and Fuel consumption
<b>Chapter</b>	<b>6</b> – Weights
<b>Chapter</b>	<b>7</b> – System Description
<b>Chapter</b>	<b>8</b> – Preservation and storage
<b>Chapter</b>	<b>9</b> – Supplement
<b>Chapter</b>	<b>10</b> – Proper disposal

**INTENTIONALLY LEFT  
BLANK**

# INTRO) Introduction

## Topics in this chapter

### **Foreword**

BRP-Rotax GmbH & Co KG (hereinafter “BRP-Rotax”) provides “Instructions for Continued Airworthiness”, which are based on the design, tests and certification of the engine and its components. These instructions apply only to engines and components supplied by BRP-Rotax.

Before operating the engine, read this Operators Manual carefully. If any passages of the Manual are not clearly understood or in case of any questions, please contact our ROTAX® Authorized Distributors or their independent Service Centers.

This Operators Manual contains important information about safe operation of the engine together with descriptions of the systems, technical data, operating media and the operational limits of the engine.

The specified information and procedures apply only to the engine and not to specific applications in particular aircraft. The aircraft manufacturers Operators Manual is therefore definitive in terms of the operation of the engine, as it contains all of the aircraft-specific instructions

BRP-Rotax wishes you much pleasure and satisfaction flying your aircraft powered by this ROTAX® aircraft engine.

### **Document structure**

The structure of the Manual follows whenever it is possible the structure of the “GAMA Specification #1 for Pilot’s Operating Handbook”.

**INTENTIONALLY LEFT  
BLANK**

## LEP) LIST OF EFFECTIVE PAGES

Each new revision to the Operators Manual will have a new List of Effective Pages.

Chapter	Page	Date	Chapter	Page	Date
	cover page			6	August 01 2019
				7	August 01 2019
INTRO	1	August 01 2019		8	August 01 2019
	2	August 01 2019		9	August 01 2019
LEP	1	August 01 2019		10	August 01 2019
	2	August 01 2019	3	1	August 01 2019
TOA	1	August 01 2019		2	August 01 2019
	2	August 01 2019		3	August 01 2019
1	1	August 01 2019		4	August 01 2019
	2	August 01 2019		5	August 01 2019
	3	August 01 2019		6	August 01 2019
	4	August 01 2019		7	August 01 2019
	5	August 01 2019		8	August 01 2019
	6	August 01 2019		9	August 01 2019
	7	August 01 2019		10	August 01 2019
	8	August 01 2019		11	August 01 2019
	9	August 01 2019		12	August 01 2019
	10	August 01 2019	4	1	August 01 2019
	11	August 01 2019		2	August 01 2019
	12	August 01 2019		3	August 01 2019
	13	August 01 2019		4	August 01 2019
	14	August 01 2019		5	August 01 2019
2	1	August 01 2019		6	August 01 2019
	2	August 01 2019		7	August 01 2019
	3	August 01 2019		8	August 01 2019
	4	August 01 2019		9	August 01 2019
	5	August 01 2019			

Chapter	Page	Date	Chapter	Page	Date	
5	10	August 01 2019		10	August 01 2019	
	11	August 01 2019		11	August 01 2019	
	12	August 01 2019		12	August 01 2019	
	1	August 01 2019		13	August 01 2019	
	2	August 01 2019		14	August 01 2019	
	3	August 01 2019		15	August 01 2019	
	4	August 01 2019		16	August 01 2019	
	5	August 01 2019		8	1	August 01 2019
	6	August 01 2019			2	August 01 2019
6	1	August 01 2019		3	August 01 2019	
	2	August 01 2019		4	August 01 2019	
7	1	August 01 2019	9	1	August 01 2019	
	2	August 01 2019		2	August 01 2019	
	3	August 01 2019	9	1	August 01 2019	
	4	August 01 2019		2	August 01 2019	
	5	August 01 2019	10	1	August 01 2019	
	6	August 01 2019		2	August 01 2019	
	7	August 01 2019		Index		
	8	August 01 2019		rear page		
	9	August 01 2019				

## TOA) Table of amendments

### Approval\*

The technical content of this documents is approved under the authority of DOA ref. EASA.21J.048. This document is part of the ICA for product [1996]

Edition 3 / Rev. 0 August 01 2019

Rev. no.	Chapter	Page	Date of change	Remark for approval	Date of approval from authorities	Date of inclusion	Signature
0	INTRO	all	Aug. 01 2019	DOA*			
0	LEP	all	Aug. 01 2019	DOA*			
0	TOA	all	Aug. 01 2019	DOA*			
0	1 up to 10	all	Aug. 01 2019	DOA*			

## Summary of amendments

Summary of the relevant amendments in this context, but without any claim to completeness.

Rev. no.	Chapter	Page	Date of change	Comments
0	1 up to 10	all	Aug. 01 2019	new layout and change of company name, also changes in chapter structure

# 1) General note

## Topics in this chapter

1.1 General .....	2
1.2 Abbreviations and terms .....	3
1.3 Safety .....	7
1.4 Safety information .....	9
1.5 Technical documentation.....	12
1.6 Type description.....	14

## 1.1) General

### Purpose

The purpose of this Operators Manual is to familiarize the aircraft manufacturers installing this aircraft engine with operating instructions and safety information.

This document is not intended for use by end customers (private aircraft owners, flight schools...) for operating the engine. Due to various executions of engine installations, only the aircraft manufacturer is able to provide end customers with operation and safety information tailored for a specific aircraft.

Nevertheless, all provided information in this Operators Manual (such as operating limits, safety information, operation instructions...) must be adhered to. The aircraft manufacturer is obliged to forward this information to the end customer in an appropriate way (e.g. within the aircraft specific Operators Manual).

For detailed information related to aircraft and aircraft/engine installation, maintenance, safety or flight operation, consult the documentation provided by the aircraft manufacturer and/or its dealer.

For additional information on engines, their maintenance or parts, you can also contact your nearest ROTAX® authorized aircraft engines distributor or their independent Service Center.

### Engine serial number

When making inquiries or ordering parts, always indicate the engine serial number. Due to continuous product improvement, engines of the same engine type might require different support and spare parts.

The engine serial number is located on the top of the crankcase, magneto side.

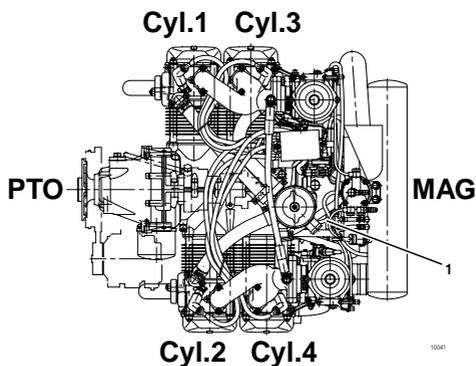

Figure 1: Pos. 1: Engine serial number

## 1.2) Abbreviations and terms

Abbreviations	Description
*	Reference to another section
	center of gravity
	The drop symbol indicates use of sealing agents, adhesives or lubricants (only in the Illustrated Parts Catalog).
°C	Degrees Celsius (Centigrade)
°F	Degrees Fahrenheit
rpm	Revolutions per minute
A	Ampere
AAPTS	Ambient Air Pressure Temperature Sensor
AC	alternating current
AD	Airworthiness Directives
Ah	Ampere hour
A/C	Aircraft
AR	as required
assy.	assembly
ASB	Alert Service Bulletin
ACG	Austro Control GmbH
ACL	Anti Collision Light
API	American Petrol Institute
ASTM	American Society for Testing and Materials
ATA	Air Transport Association
AWG	American Wire Gauge
CAN	Controller Area Network
Coil 1–4	Ignition coils 1–4
CPS 1+2	Crankshaft Position Sensor 1+2
CSA	Constant Speed Actuator
CTS	Cooling Temperature Sensor
CW	clockwise

CCW	counter-clockwise
CGSB	Canadian General Standards Board
DCDI	Dual Capacitor Discharge Ignition
DC	direct current
DOA	Design Organisation Approval
DOT	Department of Transport
EASA	European Aviation Safety Agency
IM	Installation Manual
ECU	Engine Control Unit
EGT	Exhaust Gas Temperature
INTRO	Introduction
EMS	Engine Management System
EMS GND	Engine system internal ground reference which is intended to be disconnected from aircraft common ground during flight
EMC	Electromagnetic compatibility
EN	European Standard
ETFE	Ethylene Tetrafluoroethylene
FAA	Federal Aviation Administration
FAR	Federal Aviation Regulations
FOD	Foreign object damage
Fuse box	Power conditioning and distribution for the Engine Management System
hr.	hours
HIC A	Harness Interface Connector A
HIC B	Harness Interface Connector B
IAT	Indicated Air Temperature
ICA	Instructions for Continued Airworthiness
IFR	Instrument Flight Rules
IFSD	In-flight-shutdown
INJ 1–8	Injector 1–8
IPC	Illustrated Parts Catalog

ips	inch per second
iRMT	independent ROTAX Maintenance Training
ISA	International Standard Atmosphere
kg	Kilograms
KNOCK	Knock sensor
Lane A	System A of Engine Management System
Lane B	System B of Engine Management System
LOPC	Loss of power control
MAPS 1 & 2	Manifold Air Pressure Sensor 1 & 2
MATS 1 & 2	Manifold Air Temperature Sensor 1 & 2
MON	Motor Octane Number
MAG	Magneto Side
N	Newton
n.a.	not available
NDT	Non Destructive Testing
Nm	Newtonmeter
NVFR	Night Visual Flight Rules
OAT	Organic Acid (Additive) Technology
OHM	Overhaul Manual
OHV	Over Head Valve
OM	Operators Manual
OPS	Oil Pressure Sensor
OTS	Oil Temperature Sensor
PCD	Pitch Circle Diameters
PCV	Pressure Control Valve
PMA	Permanent magnet alternator
POA	Production Organisation Approval
PS	Power supply
PTFE	Polytetrafluoroethylene (Teflon)
PTO	Power Take Off
Rev.	Revision

ROTAX®	is a trademark of BRP-Rotax GmbH & Co KG
RON	Research Octane Number
RON 424	ROTAX® Standard 424
s.v.	still valid (only Illustrated Parts Catalog)
S/N	Serial Number
SAE	Society of Automotive Engineers
SEP	Single Engine Piston
SB	Service Bulletin
SI	Service Instruction
SI-PAC	Service Instruction Parts and Accessories
SPST	Single pole single throw
STP	Shield twisted pair
SL	Service Letter
SMD	Surface Mounted Devices
TBO	Time Between Overhaul
TC	Type certificate
part no.	part number
TOA	Table Of Amendments
TOC	Table of content
TPS	Throttle Position Sensor
TSN	Time Since New
TSNP	Time Since New Part
TSO	Time Since Overhaul
V	Volt
VFR	Visual Flight Rules
LEP	List of Effective Pages
MM	Maintenance Manual
MEP	Multi Engine Piston
X3	Connector on Engine Management System wiring harness which serves as an interface for power supply
XXXX	shows the serial component number

## 1.3) Safety

Although reading such information does not eliminate any hazards, it promotes understanding, and applying the information will promote correct use of the engine. Always apply common workshop safety rules.

The information and descriptions of components and systems contained in this Manual are correct at the time of publication. BRP-Rotax maintains a policy of continuous improvement of its products without imposing upon itself any obligation to retrofit products previously manufactured.

### Revisions

BRP-Rotax reserves the right to remove, replace or discontinue any design, specification, feature or other at any time, and without incurring obligation.

### Measurement

Specifications are given in the SI metric system with the imperial and US customary measurement system equivalents in parenthesis.

### Symbols used

This Manual uses the following symbols to emphasize particular information. This information is important and must be observed.

#### **⚠ WARNING**

**Identifies an instruction which, if not followed, may cause serious injury or even fatal injury.**

#### **⚠ CAUTION**

**Identifies an instruction which, if not followed, may cause minor or moderate injury.**

#### **ATTENTION**

**Identifies an instruction which, if not followed, may severely damage the engine or could void any warranty.**

### **NOTE**

*Indicates supplementary information which may be needed to fully complete or understand an instruction.*

**ENVIRONMENTAL NOTE**

**Environmental notes give you tips on environmental protection.**

A revision bar outside the page margin indicates a change to text or graphic.

## 1.4) Safety information

Use for intended  
purpose

### **⚠ WARNING**

#### **Non-compliance can result in serious injuries or death!**

Never fly the aircraft equipped with this engine at locations, air speeds, altitudes or in other situations which do not allow a successful no-power landing after sudden engine stoppage.

- This engine is not suitable for acrobatics (inverted flight, etc.). Flight attitudes outside the permissible limits are not allowed.
- This engine has exclusively been developed and tested for gyrocopter, pusher and tractor applications. In case of any other usage, the OEM is responsible for testing and the correct function of the engine.
- It should be clearly understood that the choice, selection and use of this particular engine on any aircraft is at the sole discretion and responsibility of the aircraft manufacturer, assembler and owner/user.
- Due to the varying designs, equipment and types of aircraft, BRP-Rotax grants no warranty on the suitability of its engine's use on any particular aircraft. Further, BRP-Rotax grants no warranty on this engine's suitability with any other part, components or system which may be selected by the aircraft manufacturer, assembler or user for aircraft application.

### **⚠ WARNING**

#### **Non-compliance can result in serious injuries or death!**

For each use of DAY VFR, NIGHT VFR or IFR in an aircraft the applicable legal requirements and other existing must be adhered to.

- Certain areas, altitudes and conditions present greater risk than others. The engine may require humidity or dust/sand preventative equipment, or additional maintenance may be required.
- You should be aware that any engine may seize or stall at any time. This could lead to a crash landing and possible severe injury or death. For this reason, we recommend strict compliance with the maintenance and operation and any additional information which may be given to you by your dealer.

- Training**
- Whether you are a qualified pilot or a novice, complete knowledge of the aircraft, its controls and operation is mandatory before a solo flight. Flying any type of aircraft involves a certain amount of risk. Be informed and prepared for any situation or hazard associated with flying.
  - A recognized training program and continued education for piloting an aircraft is absolutely necessary for all aircraft pilots. Make sure you also obtain as much information as possible about your aircraft, its maintenance and operation from your dealer.
  - Engine-specific training courses are provided by the authorized distributors according to manufacturer specifications (iRMT).
- Regulations**
- Respect all legal requirements or local rules pertaining to flight operation in your flying area. Only fly when and where conditions, topography, and airspeeds are safest.
  - Consult your aircraft dealer or manufacturer and obtain the necessary information, especially before flying in new areas.
- Instrumentation**
- Select and use proper aircraft instrumentation. This instrumentation is not included in the ROTAX® engine package. Verification to the latest regulations such as FAR or EASA has to be conducted by the aircraft manufacturer.
- Engine log book**
- Keep an engine log book and respect engine and aircraft maintenance schedules. Keep the engine in top operating condition at all times. Do not operate any aircraft which is not properly maintained or has engine operating irregularities which have not been corrected.
- Maintenance (iRMT)**
- Since special training, tools and equipment are required, engine servicing shall only be performed by an authorized ROTAX® aircraft engine distributor or their independent service center. BRP-Rotax requires that any service or maintenance work be carried out and verified by a technician that has a current iRMT rating.
  - When the engine will not be operated for a longer period protect the engine and fuel system from contamination and environmental exposure.
- Engine operation**
- Never operate the engine without sufficient quantities of operating fluids (oil, coolant, fuel).
  - Never exceed the maximum permitted operational limits.
  - In the interest of safety, the aircraft must not be left unattended while the engine is running.

- To eliminate the risk of injury or damage, ensure any loose equipment or tools are properly secured before starting the engine.
- Allow the engine to cool at idle for several minutes before turning off the engine.

**Vacuum pump**

- This engine may be equipped with a vacuum pump. The safety warning accompanying the vacuum pump must be given to the owner/operator of the aircraft into which the vacuum pump is installed.

## 1.5) Technical documentation

These documents form the instructions ensuring continued airworthiness of ROTAX® aircraft engines.

The information contained herein is based on data and experience that are considered applicable for authorized mechanics (iRMT, see Maintenance Manual Line) under normal conditions. Due to the fast technical progress and fulfillment of particular specifications of the customers it may occur that existing laws, safety prescriptions, constructional and operational regulations may not be sufficient or cannot be transferred completely to the object bought, in particular for special constructions.

### Documentation

- Installation Manual
- Operators Manual
- Maintenance Manual (Line and Heavy Maintenance)
- Overhaul Manual
- Illustrated Parts Catalog
- Alert Service Bulletins
- Service Bulletins
- Service Instructions
- Service Instruction–Parts and Accessories
- Service Letters



### Status

The status of Manuals can be determined by checking the table of amendments. The first column of this table indicates the revision status which should be compared with the revision provided on the ROTAX®-Website: [www.FLYROTAX.com](http://www.FLYROTAX.com) Amendments and current versions can be downloaded free of charge.

### Replacement pages

Furthermore the Manual is constructed in such a way that single pages can be replaced instead of the complete document. The list of effective pages is given in the chapter LEP. The particular edition and revision number is given on the footer of each page.

### Reference

Any reference to a document refers to the latest edition issued by BRP-Rotax if not stated otherwise.



This symbol informs you of additional references (data sheets, Manuals, etc.) associated with the given subject.

## Illustrations

The illustrations in this Manual are merely sketches and show typical arrangements. They may not represent full detail or the exact shape of the parts but should outline the same or similar function. Therefore deriving dimensions or other details from illustrations is not permitted.

TYPICAL indicates a general view which may not represent exact details..

### NOTE

*The Illustrations in this Manual are stored in a graphic data base system and are provided with a consecutive irrelevant number.*

*This number (e.g. AE 5iS001) is of no significance for the content.*

## 1.6) Type description

The type description is made up the following.

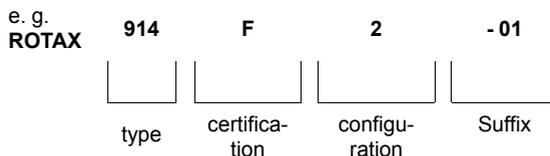

### Designation

Designation		Description
<b>Type</b>	<b>914</b>	4-cyl. horizontally opposed, turbocharged engine
<b>Certifica- tion</b>	<b>F</b>	Certified to FAR 33 (TC No. E00058EN), JAR-E (TC No. EASA.E.122)
	<b>UL</b>	Non certified aircraft engines
<b>Configura- tion</b>	<b>2</b>	Prop shaft with flange for fixed pitch propeller
	<b>3</b>	Prop shaft with flange for constant speed propeller and drive for hydraulic governor for constant speed propeller
<b>Suffix</b>	<b>- XX</b>	Explanation of the type designation Suffix, see SB-914-049.

### Options

Optional extras to the above stated basic type:

	<b>exter- nal al- terna- tor</b>	<b>vacuum pump</b>	<b>drive for rev coun- ter/ hour meter</b>	<b>gover- nor</b>
<b>for configura- tion 2</b>	yes	yes	yes	no
<b>for configura- tion 3</b>	yes	no	yes	yes

### NOTE

*Conversion of the configuration 2 to configuration 3 and vice versa may be accomplished by BRP-Rotax Authorized Distributors or their independent Service Centers.*

## 2) Operating instructions

### Topics in this chapter

<b>2.1 Operating limits</b> .....	<b>2</b>
<b>2.2 Operating media-Coolant</b> .....	<b>7</b>
<b>2.3 Operating media-Fuel</b> .....	<b>8</b>
<b>2.4 Operating media-Lubricants</b> .....	<b>9</b>

The data of the certified engine are based on the type certificate of type 914 F JAR 33 (TC No. E00058NE), JAR-E (TC No. EASA.E. 122).

### **Introduction**

The operating limits for certified engines are also given in the type certificate for the relevant engine type.  
This chapter of the Operators Manual contains the operating limits that must be observed and adhered to while operating this type of engine.

## 2.1) Operating limits

### General

#### ATTENTION

Monitor Operating limits. Limits must not be exceeded. If one or more operating limits are exceeded, the engine must be operated so that the values fall back into the allowed range. Carry out instructions for abnormal operation

performance is measured under following boundary conditions:

- Standard engine (incl. input rating for governor). Without auxiliary equipment (e.g. external alternator)
- Installation in accordance with installation guidelines (e.g. intake and exhaust system).



See latest Installation Manual for the engine type 914 Series.

- ISA Condition(International **S**tandard **A**tmosphere)

### Performance

Performance data relate to ISA (International Standard Atmosphere) conditions without Governor, external alternator etc.

Take-off performance	84.5 kW at 5800 rpm
Max. continuous performance	73.5 kW at 5500 rpm

#### Manifold pressure

Take-off performance	1300 hPa (38.4 in HG)
	1320 hPa(39.0 in HG) <sup>1</sup>
Max. continuous performance	1150 hPa (34.0 in HG)
	1180 hPa (34.9 in HG) <sup>1</sup>

#### NOTE

*The stated pressure in the suction tube is always lower by the pressure loss in the carburetors than the TCU controlled airbox pressure and may be therefore subject bigger deviations.*

1. 914 F starting with engine 4420200 (TCU part no. 966741)  
914 UL starting with engine 4417598 (TCU part no. 966741)

## Engine speed

Take-off speed	5800 rpm (max. 5 min.)
Max. continuous speed	5500 rpm
Idle speed	min. 1400 rpm

## Manifold pressure

ATTENTION	
<b>Due to the control behavior an overshooting of the manifold pressure is possible. But within 2 seconds this pressure has to stabilize within the allowance.</b>	

Take-off performance	max. 1350 hPa (39.9 in.HG)
Max. continuous performance	max. 1200 hPa (35.4 in.HG)

## Acceleration

Limit of engine operation at zero gravity and in **negative “g”** condition.

Max.	-0.5 g (max. 5 second)
------	------------------------

## Critical flying altitude

Available boost pressure

ATTENTION	
<b>Up to the stated critical flight altitude the respective manifold pressure is available.</b>	

Take-off performance	up to max. 2450 m (8000 ft) above sea level
Continuous performance	up to max. 4875 m (16000 ft) above sea level

## Airbox temperature

Airbox temperature	
Intervention temperature	72 °C (160 °F)  * 88 °C (190 °F) * 914 F starting with S/N 4420200 (TCU part no. 966741) * 914 UL starting with S/N 4417598 (TCU part no. 966741)

## Oil pressure

Max.	7 bar (102 psi)
Min.	0.8 bar (12 psi) (below 3500 rpm) 1.5 bar (22 psi) <sup>2</sup>
Normal	2.0 to 5.0 bar (29 to 73 psi) (above 3500 rpm) 1.5 to 5.0 bar (22 to 73 psi) <sup>2</sup>

### ATTENTION

**For a short period admissible at cold start.**

## Oil temperature

Max.	130 °C (266 °F)
Min.	50 °C / 120 °F
normal operating temperature	approx. 90 to 110 °C (190 – 230 °F)

## Exhaust gas temperature

Max.	950 °C (1742 °F)
------	------------------

## Conventional coolant temperature

Applicable for engine S/N without Suffix -01. See also Chapter Operating media coolant.

### Coolant temperature (coolant exit temperature)

Max.	120 °C (248 °F)
------	-----------------

### Cylinder head temperature

Max.	135 °C (275 °F)
Permanent monitoring of coolant temperature and cylinder head temperature is necessary.	

- 
2. 914 F up to S/N 4420085  
914 UL up to S/N 4417665

**Waterless coolant**

See also Chapter Operating media coolant.

<b>Cylinder head temperature</b>	
Max.	135 °C (275 °F)
Permanent monitoring of cylinder head temperature is necessary.	

**Conventional coolant**

Applicable for engine S/N with Suffix -01. See also Chapter Operating media coolant.

<b>Coolant temperature limit measured in the cylinder head</b>	<b>Engine Type</b>
Max. 120 °C (248 °F)	914 F/UL
Permanent monitoring of coolant temperature is necessary.	

**Ambient temperature**

Max. at start	50 °C (120 °F) (ambient temperature)
Min. at start	- 25 °C (- 13 °F) (oil temperature)

**Fuel pressure**

<b>⚠ WARNING</b>	
<b>Non-compliance can result in serious injuries or death!</b>	
Exceeding the max admissible fuel pressure will override the float valve of the carburetor and to engine failure.	

Max.	Airbox pressure + 0.35 bar (5.08 psi)
Min.	Airbox pressure + 0.15 bar (2.18 psi)
Normal	Airbox pressure + 0.25 bar (3.63 psi)

**Propeller governor**

<b>Power consumption of the hydraulic propeller governor</b>	
Max.	600 W

**Vacuum pump**

<b>Power consumption of the vacuum pump</b>	
Max.	300 W

**External alternator**

<b>Power consumption of the external alternator</b>	
Max.	1200 W

**Static roll angle**

The dry sump lubrication system warrants lubrication in every flight situation below maximum static roll angle.

<b>Parameter</b>	<b>Min.</b>	<b>Max.</b>
Static roll angle $\beta$		40°

## 2.2) Operating media-Coolant

### ATTENTION

**Obey the latest edition of Service Instruction SI-914-019, for the selection of the correct operating media.**

#### Conventional coolant

Conventional coolant mixed with water has the advantage of a higher specific thermal capacity than water-less coolant.

#### Application

When correctly applied, there is sufficient protection against vapor bubble formation, freezing or thickening of the coolant within the operating limits.

Use the coolant specified in the manufacturer's documentation.

#### Mixture

### ATTENTION

**Obey the operating media manufacturer's instructions!**

Applicable for engine S/N without Suffix -01.

Designation	Mixture ratio %	
	Concentrate	Water
conventional e.g. BASF Glysantine anticorrosion	50*	50
waterless e.g. Aero Cool 180°	100	0

\* coolant component can be increased up to max. 65 %.

Applicable for engine S/N with Suffix -01.

Designation	Mixture ratio %	
	Concentrate	Water
conventional e.g. BASF Glysantine anticorrosion	50*	50

\* coolant component can be increased up to max. 65 %.

## 2.3) Operating media-Fuel

### ATTENTION

Obey the latest edition of Service Instruction SI-914-019, for the selection of the correct operating media.

### ATTENTION

Use only fuel suitable for the respective climatic zone.

### NOTE

*Risk of vapour formation if using winter fuel for summer operation.*

The fuels with following specifications can be used:

#### Antiknock properties

	Usage/Description
Anti knock properties	914 F/UL
	Min. RON 95

### NOTE

*For fuels according to ASTM D4814 specifications following AKI (Anti Knock Index) value has to be observed: min. AKI 91.*

#### MOGAS

	Usage/Description
<b>MOGAS</b>	<b>914 F/UL</b>
European standard	EN 228 Super EN 228 Super plus

#### AVGAS

AVGAS 100LL places greater stress on the valve seats due to its high lead content and forms increased deposits in the combustion chamber and lead sediments in the oil system.

	Usage/Description
<b>AVGAS</b>	<b>914 F/UL</b>
Aviation standard	AVGAS 100 LL (ASTM D910)

## 2.4) Operating media-Lubricants

### ATTENTION

**Obey the manufacturer's instructions about the lubricants.** If the engine is mainly run on AVGAS more frequent oil changes will be required. See Service Information SI-914-019, latest edition.

#### Oil type



At the selection of suitable lubricants refer to the additional information in the Service Information SI-914-019, latest edition.

#### Oil consumption

Max. 0.06 l/h (0.13 liq pt/h)

#### Oil specification

- Use only oil with RON 424 classification

#### NOTE

*The ROTAX® Norm 424 (RON 424) is a BRP-Rotax internal standard, which is only available on special request via the ROTAX® authorized distributor and will not be disclosed to third parties without prior consent.*

- Due to the high stresses in the reduction gears, oils with gear additives such as high performance motor cycle oils are required.
- Because of the incorporated overload clutch, oils with friction modifier additives are unsuitable as this could result in clutch slippage during normal operation.
- Heavy duty 4-stroke motor cycle oils meet most of the requirements. These oils are normally not mineral oils but semi- or full synthetic oils.
- Oils primarily for Diesel engines have **insufficient high temperature properties and additives which favour clutch slipping, and are generally unsuitable.**

#### Oil viscosity

Use of multi-grade oils is recommended.

#### NOTE

*Multi-viscosity grade oils are less sensitive to temperature variations than single grade oils.*

*They are suitable for use throughout the seasons, ensure rapid lubrication of all engine components at cold start and get less fluid at higher temperatures.*

**Table of lubrication**

Since the temperature range of neighboring SAE grades overlap, there is no need for change of oil viscosity at short duration of ambient temperature fluctuations.

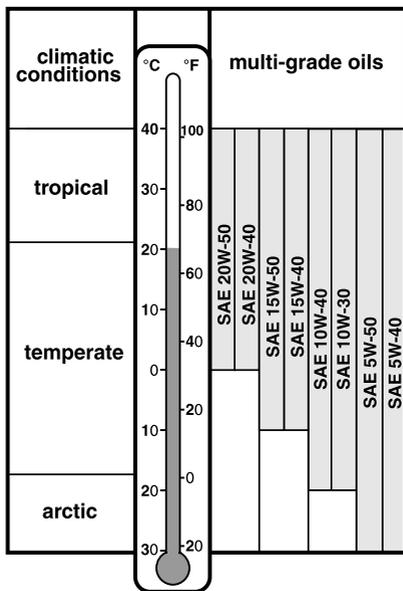

AE 2\_0064

Figure 1: Temperature range

### 3) Standard operation

#### Topics in this chapter

3.1 Daily checks .....	2
3.2 Before engine start .....	5
3.3 Pre-flight checks .....	5
3.4 Engine start .....	6
3.5 After engine start .....	8
3.6 Take-off .....	10
3.7 Take-off (standard - with activated servo motor of the TCU) .....	10
3.8 Take-off (as per RTCA DO 178 B - with deactivated servo motor of the TCU) .....	10
3.9 Cruising .....	11
3.10 Engine shut-off .....	11
3.11 Cold weather operation .....	11

#### Introduction

To warrant reliability and efficiency of the engine, meet and carefully observe all the operating and maintenance instructions.

The following description of procedures depends on the respective type of installation in the aircraft and shall therefore only be seen functionally.

#### **NOTE**

*The control elements mentioned in this chapter are only symbolic and should support the understanding of the procedures. The execution of control elements is in the responsibility of the aircraft manufacturer.*

### 3.1) Daily checks

#### Safety

To warrant reliability and efficiency of the engine, meet and carefully observe all the operating and maintenance instructions.

#### ⚠ WARNING

**Risk of burnings and scalds! Hot engine parts!**  
Conduct checks on the cold engine only!

#### ⚠ WARNING

**Non-compliance can result in serious injuries or death!**  
Ignition "OFF" Before moving the propeller switch off both ignition circuit and secure the aircraft. Have the cockpit occupied by a competent person.

#### ATTENTION

**If established abnormalities (e.g. excessive resistance of the engine, noise etc.) inspection in accordance with the relevant Maintenance Manual is necessary. Do not release the engine into service before rectification.**

#### Coolant level

#### ATTENTION

**Operating media must be observed.**  
Inappropriate coolant quantity can lead to serious engine damage.

The specifications given in [Chapter 2.2](#) must be adhered to when refilling coolant.

Step	Procedure
1	Verify coolant level in the <b>expansion tank</b> , replenish as required up to top. The max. coolant level must be flush with the bottom of the filler neck.
2	Verify coolant level in the <b>overflow bottle</b> , replenish as required. The coolant level must be between max. and min. mark.

#### ENVIRONMENTAL NOTE

**Protect the environment!**  
Do not harm the environment by spilling coolant. Dispose coolant in an environmentally friendly manner.

## Expansion tank

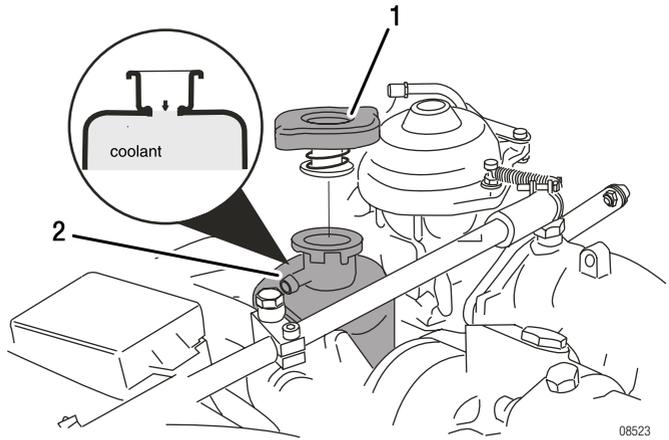

08523

Figure 1: Expansion tank

1 Radiator cap

2 Expansion tank

## Overflow bottle

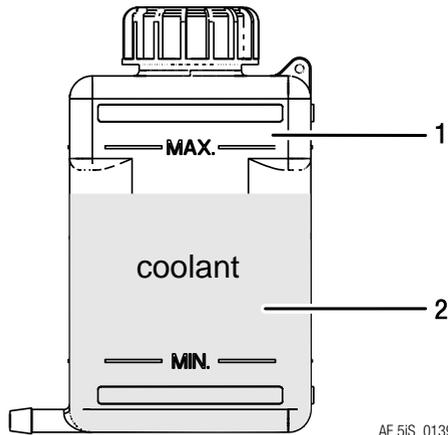

AE 5IS\_0139

Figure 2: Overflow bottle

1 Overflow bottle

2 Coolant

Step	Procedure
1	<p><b>NOTE</b></p> <p><i>Propeller shouldn't be turned in reverse of the normal direction of engine rotation.</i></p> <p>Turn propeller slowly by hand in direction of engine rotation several times and observe engine for odd noises or excessive resistance and normal compression.</p>
2	Verify free movement of throttle valves over the complete range.
3	Inspect for damages, leakage and general condition of exhaust system and turbocharger.
4	Visual inspection for mechanical and thermal damages of sensor, actuators and the wiring harness.

ATTENTION
<p><b>At excessive resistance of the engine perform the relevant unscheduled maintenance check according to Maintenance Manual (Line), chapter "Hard to turn over".</b></p>

**Gearbox**

Version **without** overload clutch:  
No further checks are necessary.

Version **with** overload clutch:

Step	Procedure
1	Turn the propeller by hand to and from, feeling the free rotation of 30° before the crankshaft starts to rotate. If propeller can be turned between the dogs frictionless (lower than 25 Nm (19 ft.lb)), further inspection is required.

**Carburetor**

Step	Procedure
1	Verify free movement of throttle cable and starting carburetor over the complete range. Check from the cockpit.

## 3.2) Before engine start

Carry out pre-flight checks.

## 3.3) Pre-flight checks

### Safety

#### ⚠ WARNING

**Non-compliance can result in serious injuries or death!**  
Ignition "OFF" Before moving the propeller switch off both ignition circuit and secure the aircraft. Have the cockpit occupied by a competent person.

#### ⚠ WARNING

**Risk of burnings and scalds! Hot engine parts!**  
Conduct checks on the cold engine only!

### Operating media

Step	Procedure
1	Check for any oil-, coolant- and fuel leaks. If leaks are evident, rectify and repair them before next flight.

### Oil level

#### ATTENTION

**Operating media must be observed.**  
Inappropriate oil quantity can lead to serious engine damage.

The specifications given in [Chapter 2.4](#) must be adhered to when refilling oil.

Step	Procedure
1	<b>NOTE</b> <i>Propeller shouldn't be turned in reverse of the normal direction of engine rotation.</i> Remove bayonet cap from the oil tank, turn the propeller slowly by hand in direction of engine rotation several times to pump residual oil from the engine into the oil tank.
2	It is essential to build up compression in the combustion chamber. Maintain the pressure for a few seconds to let the gas flow via the piston rings into the crankcase. The

Step	Procedure
	speed of rotation is not important but rather the continuous pressure and the amount of gas which is transferred into the crankcase.
3	This process is finished when air is returning back to the oil tank and can be noticed by an audible gurgle from the open oil tank.
4	Check oil level and add oil if necessary. The oil level should be in the upper half (between the "50%" and the "max" mark) and should not fall below the "min." mark of the oil dipstick. Prior to long flights oil should be added so that the oil level reaches the "max" mark. Avoid oil levels exceeding the "max" mark, since excess oil could be poured out through the venting system. Difference between max.- and min.- mark = 0.45 litre (0.95 liq pt). Oil consumption max 0.06 l/h (0.13 liq pt/h).
5	Re-install bayonet cap.

#### ENVIRONMENTAL NOTE

##### Protect the environment.

Do not harm the environment by spilling oil. Dispose of oil in an environmentally friendly manner.

## 3.4) Engine start

#### ⚠ WARNING

##### Non-compliance can result in serious injuries or death!

Do not start the engine if any person is near the engine.

### Engine start

Step	Designation	Procedure
1	Fuel valve.	open
2	Starting carb.	activated
	<b>If</b> engine in operating temperature.	<b>Then</b> start the engine without choke.
3	Throttle lever.	Set to idle position.
4	Master switch.	ON

TCU

Function test of TCU

**NOTE**

*When switching on the voltage supply, both lamps are automatically subject to a function test.*

Lamps

For approx. 1-2 seconds both lamps illuminate and then extinguish. If not, a check as per Maintenance Manual is necessary.

ATTENTION		
<b>If abnormalities are found inspection in accordance with the relevant Maintenance Manual is necessary. Do not release the engine into service before rectification.</b>		

Step	Designation	Procedure
5	Electric fuel pump.	ON
6	Ignition.	Both circuits switched on.
7	Starter button.	Actuate.

ATTENTION		
<b>Activate starter for maximum of 10 consecutive seconds only, followed by a cooling period of 2 minutes.</b>		

Step	Designation	Procedure
8	As soon as engine runs.	Release starter button and adjust throttle to achieve smooth running at approx. 2500 r.p.m.
9	Oil pressure.	Check if oil pressure has risen within 10 seconds and monitor oil pressure. Increase of engine speed is only permitted at steady oil pressure readings above 2 bar (30 psi).

**ATTENTION**

**At an engine start with low oil temperature, continue to observe the oil pressure as it could drop again due to the increased flow resistance in the suction line. Engine rpm may only be increased so far as the oil pressure re-mains steady.**

Step	Designation	Procedure
10	Starting carb (choke)	De-activate and adjust engine rpm as necessary.

To observe

Reduction gear with shock absorber

**ATTENTION**

**Since the engine comprises a reduction gear with shock absorber, take special care of the following:**

Step	Procedure
1	To prevent impact load, start with throttle lever in idle position or at the most up to 10% open.
2	For the same reason, wait for around 3 sec. after throttling back to partial load to reach constant speed before re-acceleration.
3	While checking the two ignition circuits, only one circuit may be switched off at a time.

### 3.5) After engine start

**⚠ WARNING**

**Non-compliance can result in serious injuries or death!**  
Do not start the engine if any person is near the engine.

Warming up period

Step	Procedure
1	Start warming up period at approx. 2000 rpm for approx. 2 minutes.
2	Continue at 2500 rpm, duration depending on ambient temperature, until oil temperature reaches 50 °C (120 ° F).
3	Check temperatures and pressure.

## Throttle response

### ATTENTION

**After a full-load ground test allow a cooling run at idle speed to prevent vapour formation in the cylinder head.**

Step	Procedure
1	Full throttle ground test (consult Aircraft Operators Manual since engine speed depends on the propeller used).

## Ignition check

After engine warm – up and prior to take –off, check the two ignition circuits at **4000 rpm** (approx. 1700 rpm propeller).

Step	Procedure
1	Speed (engine rpm) drop with only one ignition circuit must not exceed <b>500 rpm</b> (approx. 210 rpm propeller).
2	<b>150 rpm</b> (approx. 65 rpm propeller) max. difference of speed (engine rpm) by use of either circuit, A or B.

### NOTE

*The propeller speed depends on the actual reduction ratio.*

## Propeller governor

### Check of hydraulic propeller governor:

Check control of the hydraulic propeller governor to specifications of the manufacturer.

### NOTE

*Cycling the propeller governor puts a relatively high load on the engine. Unnecessary cycling or additional checks should be avoided.*

### 3.6) Take-off

#### ⚠ WARNING

**Non-compliance can result in serious injuries or death!**  
Monitor Operating limits. Limits must not be exceeded.

Respect “cold weather operation” recommendations. see [Chapter 3.9 Cold weather operation](#).

#### ATTENTION

If the national Aviation Authority demands the software classification “D” according to RTCA DO 178 B for the TCU software a special starting procedure is laid down which renders any influence of the TCU ineffective during the take-off.

#### Climb

Climbing with engine running at take-off performance is permissible (max. 5 minutes).

See [Chapter 2.1 Operating limits](#)

### 3.7) Take-off (standard - with activated servo motor of the TCU)

Step	Procedure
1	Switch on the auxiliary fuel pump at take-off.
2	Move throttle lever to 115 % (take-off performance).
3	The auxiliary fuel pump should be switched off after reaching the safety altitude.

### 3.8) Take-off (as per RTCA DO 178 B - with deactivated servo motor of the TCU)

#### ATTENTION

Any improper use of the TCU-switch will be recorded by the TCU. At exceeding of the limits of operation will render any claims on RO-TAX® null and void.

Step	Procedure
1	Switch on the auxiliary fuel pump at take-off.
2	Move throttle lever to 115 % (take-off performance).
3	Set take-off power until the boost pressure stabilizes within the limits of operation.

Step	Procedure
4	TCU-switch to "OFF" position.
5	After reaching the minimum safe altitude switch on the TCU.
6	The auxiliary fuel pump should be switched off after reaching the safety altitude.

### 3.9) Cruising

#### Performance

Step	Procedure
1	Set performance as per performance specifications <a href="#">Chapter 5</a> and respect operating limits as per <a href="#">Chapter 2.1 Operating limits</a> .

#### Oil temperature

Step	Procedure
1	Avoid operation below normal oil temperature (90 to 110 °C / 194 to 230 °F), as possible formation of condensation water in the lubrication system badly influences the oil quality. To evaporate possibly accumulated condensation water, at least once a day 100 °C (212 °F) oil temperature must be reached.

### 3.10) Engine shut-off

Normally the cooling down of the engine during descending and taxiing will be sufficient to allow the engine to be shut off as soon as the aircraft is stopped.

At increased operating temperatures make an engine cooling run of at least minimum 2 minutes.

### 3.11) Cold weather operation

Generally, an engine service should be carried out before the start of the cold season.

#### Coolant

For selection of coolant and mixing ratio, see [Chapter 2.3](#).

#### Lubricant

For selection of oil, see table of Lubricants [Chapter 2.5](#).

#### Cold start

- With throttle closed and choke activated (open throttle renders starting carb ineffective)
- Be aware, no spark below crankshaft speed of 220 rpm (propeller speed of 90 rpm)

- As performance of electric starter is greatly reduced when hot, limit starting to periods not much longer than 10 sec. With a well charged battery, adding a second battery will not improve cold starts

### Remedy - Cold start

Step	Procedure
1	Use of multigrade oil with the low end viscosity code of 5 or 10.
2	Check electrode gap of spark plugs and if worn fit new spark plugs. See Maintenance Manual Line of the respective engine type.
3	Preheat engine.

### Icing in the air intake system

#### Icing due to humidity.

Carburetor icing due to humidity may occur on the venturi and on the throttle valve due to fuel evaporation and leads to performance loss and change in mixture.

#### Remedy

- Intake air pre-heating is the only effective remedy. See Flight Manual supplied by the aircraft manufacturer
- The turbocharger will heat up the intake air. If however intake air pre-heating is necessary, observe the aircraft manufacturer's engine installation and operating instruction

### Icing due to water fuel

#### Icing due to water in fuel.

ATTENTION
<p><b>Fuels containing alcohol always carry a small amount of water in solution. In case of temperature changes or increase of alcohol content, water or a mixture of alcohol and water may settle and could cause troubles.</b></p>

Water in fuel will accumulate at the lower parts of the fuel system and leads to freezing of fuel lines, filters or jets.

#### Remedy

- Use non-contaminated fuel (filtered through suede)
- Generously sized water separators
- Fuel lines routing inclined and without undrained low points
- Prevent condensation of humidity, i. e avoid temperature differences between aircraft and fuel

## 4) Abnormal operation

### Topics in this chapter

<b>4.1 Sudden drop of boost pressure and speed</b> .....	<b>3</b>
<b>4.2 Sudden rise of boost pressure and speed</b> .....	<b>3</b>
<b>4.3 Periodical rise and drop of boost pressure and speed (boost pressure control is surging)</b> .....	<b>4</b>
<b>4.4 Caution lamps</b> .....	<b>5</b>
4.4.1 Red boost lamp of TCU permanently illuminating .....	5
4.4.2 Red boost lamp of TCU blinking .....	5
4.4.3 Orange caution lamp of TCU blinking .....	6
<b>4.5 Failure of the voltage supply to the TCU</b> .....	<b>6</b>
<b>4.6 Re-Start during flight</b> .....	<b>7</b>
<b>4.7 Exceeding max. admissible engine speed</b> .....	<b>7</b>
<b>4.8 Exceeding of max. admissible cooling system temperature</b> .....	<b>7</b>
4.8.1 Exceeding of max. admissible cyl. head temperature .....	7
4.8.2 Exceeding of max. admissible coolant temperature .....	7
4.8.3 Exceeding of max. admissible oil temperature .....	8
<b>4.9 Oil pressure below minimum – during flight</b> .....	<b>8</b>
4.9.1 Oil pressure below minimum - on ground .....	8
4.9.2 Oil pressure above permitted range at low ambient temperatures .....	9
<b>4.10 Engine on fire or fire in the engine compartment</b> .....	<b>9</b>
<b>4.11 Troubleshooting</b> .....	<b>9</b>

**⚠ WARNING**

**Non-compliance can result in serious injuries or death!**

Unless stated otherwise in this chapter, operating an engine with limited airworthiness is not permitted. At unusual engine behavior conduct checks as per maintenance Manual Line Chapter 05-50-00 before the next flight. Only qualified staff (authorized by the Aviation Authorities) trained on this particular engine, is allowed to carry out maintenance and repair work.

The following description of procedures depends on the respective type of installation in the aircraft and shall therefore only be seen functionally.

## 4.1) Sudden drop of boost pressure and speed

### Sudden drop of boost pressure and speed

Any exceeding of the max. admissible engine speed or boost pressure must be recorded by the pilot in the logbook, stating the exact time and duration of exceeding.

Loud noise or bang	
Possible cause	Remedy
Fracture of the turbo	Look for landing possibility.
	Flight with reduced performance may be possible.
	Monitor oil pressure.

Orange caution lamp of TCU (turbo control unit) is blinking	
Possible cause	Remedy
Wastegate does not close	Limited flying operation as possibly wastegate does not respond.

### NOTE

*A minimum performance of approx. 66 kW (88 HP) remains available with the wastegate in the fully open position.*

## 4.2) Sudden rise of boost pressure and speed

### Sudden rise of boost pressure and speed

Any exceeding of the max. admissible engine speed or boost pressure must be recorded by the pilot in the logbook, stating the exact time and duration of exceeding.

Orange caution lamp of TCU (turbo control unit) is blinking	
Possible cause	Remedy
Wastegate fully closed	Immediately reduce engine speed until boost pressure and speed are within operating limits.
	Limited flying operation as wastegate may be fully closed and control of the boost pressure is only possible via throttle lever.

<b>Bowden cable(s) for actuation of throttle valve(s) broken</b>	
<b>Possible cause</b>	<b>Remedy</b>
Due to spring pressure the throttle valve(s) will be fully open - full throttle!	Limited flying operation as wastegate may be fully closed and control of the boost pressure and rpm is only possible via ignition unit.

### 4.3) Periodical rise and drop of boost pressure and speed (boost pressure control is surging)

**Periodical rise and drop of boost pressure and speed**

Switching off the servo motor momentarily or permanently, must be recorded by the pilot in the logbook, stating the exact time and duration of switching off.

<b>ATTENTION</b>
<b>If this action does not stabilize operation, switch off servo completely. If need be, reduce engine speed until boost pressure and speed are within the operating limits again.</b>

<b>Orange caution lamp of TCU is not blinking</b>	
<b>Possible cause</b>	<b>Remedy</b>
Pressure control is not possible.	Limited flying operation. Switch off servo motor for a moment (max. 5 sec).
	After a short regulating time operation should stabilize.

## 4.4) Caution lamps

### 4.4.1) Red boost lamp of TCU permanently illuminating

**Red boost lamp permanently illuminating**

Exceeding the max. admissible boost pressure, this must be recorded by the pilot in the logbook, stating the exact time and duration of exceeding of limits.

ATTENTION	
The boost pressure will not be reduced automatically.	
Possible cause	Remedy
The maximum admissible boost pressure was exceeded.	Reduce speed and boost pressure manually to be within the operating limits.
	Limited flying operation, as boost pressure control may be unavailable or insufficiently.

### 4.4.2) Red boost lamp of TCU blinking

**Red boost lamp blinking**

Exceeding the "take-off" time limits, this must be recorded by the pilot in the logbook, stating the exact time and duration of exceeding of limits.

ATTENTION	
The boost pressure will not be reduced automatically.	
Possible cause	Remedy
The maximum "take-off" time limitation was exceeded.	Reduce speed and boost pressure at least to maximum continuous speed.  <b>NOTE</b> <i>After a short regulating time, the blinking red boost lamp should extinguish.</i>

### 4.4.3) Orange caution lamp of TCU blinking

In case of an orange blinking TCU caution lamp.

Required pilot action:

- Observe engine speed and manifold pressure
- If engine speed and manifold pressure are outside of the operating limits — reduce speed and boost pressure manually to be within the operating limits
- If the manual adjustment of manifold pressure and speed is not possible anymore the servo motor of the turbo charger waste gate need to be switched **OFF**

#### ATTENTION

**Flight characteristics may be affected, as this indicates that the boost pressure control doesn't work properly.**

A blinking orange TCU caution lamp has to be recorded by the pilot in corresponding documentation (e.g. engine and/or aircraft logbook). Subsequent maintenance action is required.

The specific pilot action also depends on aircraft related installation situation (operational conditions, additional installation provisions, etc.) and can not be determined at the engine manufacturing level and therefore must be established at the aircraft manufacturer's level.

### 4.5) Failure of the voltage supply to the TCU

#### Failure of the voltage supply

At a failure of voltage supply the servo motor will remain in its momentary position.

- Wiring shortcomings in installation, switching of voltage supply etc. may cause a failure of voltage supply. In accordance with the instructions of the aircraft manufacturer the cause for failure of voltage supply needs to be verified. First pilot action would be to make sure that voltage supply is activated. If failure still remains, the power setting needs to be adapted as required.
- Limited flight operation need to be considered as boost pressure control is not possible.

Any exceeding of the max. admissible operating limits must be recorded by the pilot in the logbook, stating the duration, exact time and extent of exceeding.

## 4.6) Re-Start during flight

If the propeller continues to rotate during flight by windmilling, but the speed is not sufficient to start the engine, the electric starter can be used. It is not required to wait until the propeller stops rotating.

## 4.7) Exceeding max. admissible engine speed

### Exceeding engine speed

Reduce the engine speed. Any exceeding of the max. admissible engine speed must be entered by the pilot into logbook, stating the exact time and duration of engine over speed.

- A maintenance inspection should be carried out

## 4.8) Exceeding of max. admissible cooling system temperature

### ATTENTION

Reduce engine power setting to the minimum necessary and carry out precautionary landing.

## 4.8.1) Exceeding of max. admissible cyl. head temperature

### ATTENTION

Reduce engine power setting to the minimum necessary and carry out precautionary landing.

### Cylinder head temperature max.

Applicable for engine S/N without Suffix -01.

- Any exceeding of the max. admissible cylinder head temperature must be entered by the pilot into the logbook, stating duration and extent of over-temperature condition.
- Carry out an unscheduled maintenance check according to Maintenance Manual Line chapter 05-50-00.

## 4.8.2) Exceeding of max. admissible coolant temperature

### ATTENTION

Reduce engine power setting to the minimum necessary and carry out precautionary landing.

### Coolant temperature max.

Applicable for engine S/N with Suffix -01.

- Any exceeding of the max. admissible coolant temperature must be entered by the pilot into the logbook, stating duration and extent of over-temperature condition.
- Carry out an unscheduled maintenance check according to Maintenance Manual Line chapter 05-50-00.

### 4.8.3) Exceeding of max. admissible oil temperature

<b>ATTENTION</b>
<b>Reduce engine power setting to the minimum necessary and carry out precautionary landing.</b>

#### Exceeding oil temperature

- Any exceeding of the max. oil temperature must be entered by the pilot in the logbook, stating duration and extent of over-temperature condition.
- A maintenance inspection should be carried out.

### 4.9) Oil pressure below minimum – during flight

<b>ATTENTION</b>
<b>Reduce engine power setting to the minimum necessary and carry out precautionary landing.</b>

#### Oil pressure

#### Oil pressure below minimum - during flight

- Check oil system.
- A maintenance inspection should be carried out.

### 4.9.1) Oil pressure below minimum - on ground

<b>ATTENTION</b>
<b>Reduce engine power setting to the minimum necessary and carry out precautionary landing.</b>

#### Oil pressure too low

Immediately stop the engine and check for reason. Check oil system.

- Check oil quantity in oil tank.
- Check oil quality. See Chapter: Operating media-Lubricants.
- A maintenance inspection should be carried out.

## 4.9.2) Oil pressure above permitted range at low ambient temperatures

### ATTENTION

**Reduce engine power setting to the minimum necessary and carry out precautionary landing.**

**Oil pressure too high**

- Reduce engine speed and check the oil pressure again once it has reached a higher oil temperature
- A maintenance inspection should be carried out

## 4.10) Engine on fire or fire in the engine compartment

### ATTENTION

**Carry out emergency procedures as prescribed in the flight manual of the engine manufacturer.**

- After landing locate the cause of fire and resolve the error before next flight by qualified staff (authorized by the Aviation Authorities)
- An entry in the logbook must be made
- A maintenance inspection should be carried out

## 4.11) Troubleshooting

### ⚠ WARNING

**Non-compliance can result in serious injuries or death!**  
Only qualified staff (authorized by the Aviation Authorities) trained on this particular engine, is allowed to carry out maintenance and repair work.

### ATTENTION

**If the following hints regarding remedy do not solve the problem, contact an authorized distributor. The engine must not be operated until the problem is rectified.**



All checks in accordance with the Maintenance Manual , current issue.

**Starting problems**

**Engine does not start**

<b>Possible cause</b>	<b>Remedy</b>
Ignition <b>OFF</b>	Switch <b>ON</b>
Closed fuel valve or clogged filter	Open valve, clean or renew filter, check fuel system for leaks.
No fuel in tank.	Refuel.
Starting speed too low, faulty or discharged battery	Fit fully charged battery.
Starting speed too low, start problems on cold engine.	Use top quality, low friction oil; allow for sufficient cooling period to counter for performance drop on hot starter; preheat engine.
Wrong fuel (Jetfuel or Diesel).	Change of fuel.
Fuel air-ratio to rich	Start without electric booster pump. Start without start carb (Choke).

## Engine run

### Engine keeps running while ignition switch is turned off

<b>Possible cause</b>	<b>Remedy</b>
Overheating of engine.	Let engine cool down at idling at approx. 2000 rpm.

### Knocking under load

Possible cause	Remedy
Octane rating of fuel too low.	Use fuel with higher octane rating.

### Engine idles rough after warm-up period, smoky exhaust emission.

Possible cause	Remedy
Starting carb (Choke) activated.	Close starting carb (Choke).

### Oil pressure

#### Low oil pressure

Possible cause	Remedy
Not enough oil in oil tank.	Refill oil.
Oil too hot.	Cool down oil.

#### High oil pressure

Possible cause	Remedy
Oil too cold	Cover oil cooler or install thermostat.
Wrong viscosity of oil	Change oil to lower viscosity.

### Oil level

#### Oil level is increasing

Possible cause	Remedy
Oil too cold during engine operation.	Cover oil cooler surface, maintain the oil temperature prescribed.
Contamination with diesel fuel.	Check fuel.

### Cold engine start

#### Engine hard to start at low temperature

Possible cause	Remedy
Starting speed too low.	Preheat engine.
Faulty or discharged battery.	Fit fully charged battery.

Possible cause	Remedy
High oil pressure.	At cold start an oil pressure reading of up to around 7 bar (102 psi) does not indicate a malfunction.
Oil pressure too low after cold start.	Too much resistance in the oil suction system at low temperatures due to cold oil. Stop engine and preheat oil. After a cold start the oil tank must be observed and the oil pressure should be above 1.5 bar (22 psi). Otherwise, the speed must be lowered again, because not enough cold oil can be sucked. If oil pressure is reading lower than 1 bar (15 psi) oils with lower viscosity are to be used. See SI-914–019, current issue.

### **NOTE**

*Oil pressure must be measured at idle at an oil temperature of minimum 50 °C (120 °F). Be sure the oil pressure does not go below minimum at idle.*

## 5) Performance and Fuel consumption

### Topics in this chapter

5.1 Performance data and fuel consumption .....	2
5.2 Fuel consumption .....	6

#### Introduction

The performance tables and performance graphs on the next few pages are intended to show you what kind of performance to expect from your engine in terms of power output. The indicated power can be achieved by following the procedures laid out in the Operators Manual and ensuring that the engine is well-maintained.

## 5.1) Performance data and fuel consumption

### Performance graphs

### Performance graphs for standard conditions (ISA)

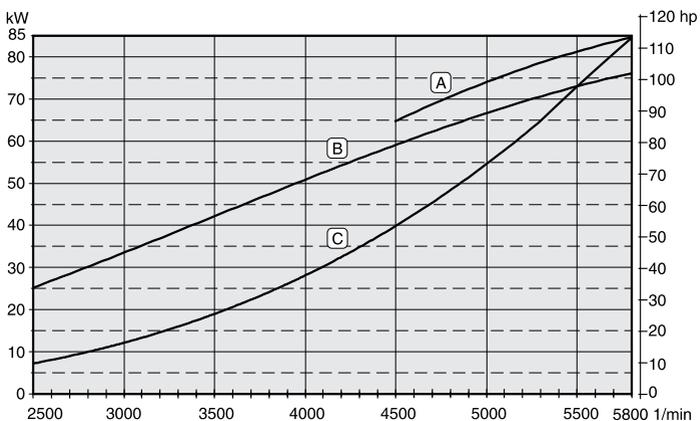

Figure 1: Performance graphs

A *Take-off performance*

B *Continuous full throttle performance*

C *Power requirement of propeller*

## NOTE

The manifold pressure in the compensating tube is always lower by the pressure loss in the carburetors than the TCU controlled airbox pressure and may be therefore subject to bigger deviations.

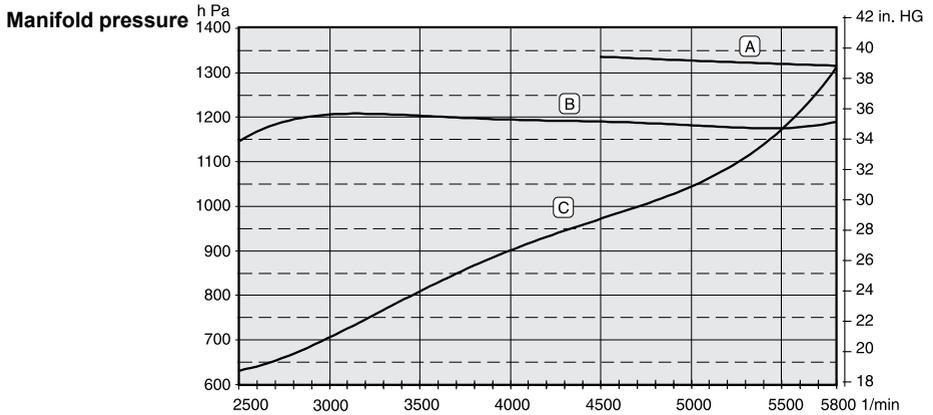

Figure 2: Manifold pressure

*Engine curve (take-off performance):*

- A 84.5 kW at 5800 rpm  
1300 hPa (38.4 in HG)  
1320 hPa (39.0 in HG)<sup>3</sup>

*Engine curve (continuous full throttle performance):*

- B 73.5 kW at 5500 rpm  
1150 hPa (34.0 in Hg)  
1180 hPa (34.9 in Hg)<sup>3</sup>

*Propeller curve*

- C (Power requirement of propeller)<sup>3</sup>

3. 914 F starting with engine 4420200 (TCU part no. 966741)  
914 UL starting with engine 4417598 (TCU part no. 966741)

**Performance data for variable pitch propeller**

Engine speed over 5500 rpm is restricted to 5 minutes.

Run the engine in accordance with the following table.

<b>Power setting</b>	<b>Engine speed (rpm)</b>	<b>Performance (kW)/ (HP)</b>	<b>Torque (Nm) (ft.lb.)</b>	<b>Manifold press. (in.HG)</b>	<b>Throttle position (%)</b>
Take-off power	5800	84.5 / 115	139 / 102	39	115.0
max. continuous power	5500	73.5 / 100	128 / 93	35	100.0
75 %	5000	55.1 / 74	105 / 77	31	approx. 67
65 %	4800	47.8 / 64	95 / 70	29	approx. 64
55 %	4300	40.4 / 54	90 / 66	28	approx. 59

**NOTE**

*Further essential information regarding engine behavior see Service Letter SL-914-014, latest edition.*



## 5.2) Fuel consumption

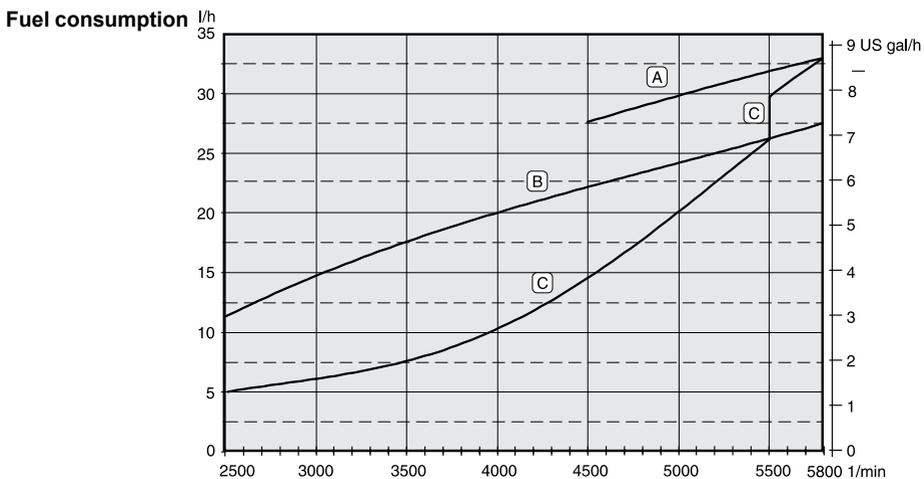

Figure 4: Fuel consumption

A *Engine curve (take-off performance)*

B *Engine curve (continuous full throttle performance)*

*Propeller curve*  
C *(Power requirement of propeller)*

## 6) Weights

### Topics in this chapter

6.1 Weight – Engine .....	1
6.2 Weight – Accessories.....	1

The stated weights are dry weights (without operating fluids) and are guide values only.



Further weight information relating to the equipment can be found in the current Installation Manual for the engine type 914 .

### 6.1) Weight – Engine

#### Engine

- **with:** carburetors, generator, ignition unit and oil tank, electric starter, stainless steel muffler, engine suspension frame, turbocharger and TCU (turbocharger control unit)
- **without:** radiator and fuel pump

Configuration 2	
914 F	914 UL
71.7 kg (158 lb)	71.7 kg (158 lb) with overload clutch
	70.0 kg (154 lb) without clutch

Configuration 3	
914 F	914 UL
74.4 kg (164 lb)	

### 6.2) Weight – Accessories

#### Accessories

Part	Weight
External alternator	3.0 kg (6.6 lb)
Vacuum pump	0.8 kg (1.8 lb)
Overload clutch	1.7 kg (3.7 lb)

#### NOTE

*The overload clutch is installed on all certified aircraft engines and on non-certified aircraft engines of the configuration 3.*

**INTENTIONALLY LEFT  
BLANK**

## 7) System Description

### Topics in this chapter

<b>7.1 General specification</b> .....	<b>2</b>
7.1.1 Basic specification .....	2
7.1.2 Auxiliary equipment (optional).....	3
7.1.3 Technical data .....	4
7.1.4 Engine components.....	4
7.1.5 Cylinder arrangement .....	5
7.1.6 Direction of rotation .....	5
<b>7.2 Cooling system</b> .....	<b>6</b>
<b>7.3 Fuel system</b> .....	<b>7</b>
<b>7.4 Lubrication system</b> .....	<b>8</b>
<b>7.5 Electric system</b> .....	<b>10</b>
<b>7.6 Turbo charger and control system</b> .....	<b>11</b>
7.6.1 TCU caution lamps.....	13
<b>7.7 Exhaust system</b> .....	<b>14</b>
<b>7.8 Propeller gearbox</b> .....	<b>15</b>

### **Introduction**

This chapter of the Operators Manual contains information about the general engine specification as well as a description of cooling system, fuel system, lubrication system, electric system and the propeller gearbox.

The system description refers only to the engine and not to a specific application in a particular aircraft. The aircraft manufacturer's Operators Manual is therefore definitive in terms of the operation of the engine, as it contains all the aircraft specific instructions.

The design shown in this chapter does not represent a specified execution but should support the understanding of the system.

## 7.1) General specification

### 7.1.1) Basic specification

#### Basic

- 4-stroke, 4 cylinder horizontally opposed, spark ignition engine with turbo charger, single central camshaft hydraulic tappets – push rods – OHV
- Liquid cooled cylinder heads
- Ram air cooled cylinders
- Dry sump forced lubrication
- Dual ignition of breakerless capacitor discharge design
- 2 constant depression carburetors and airbox
- 2 electric fuel pumps (12 V DC)
- Electric starter (standard or starter with extended power output)
- Stainless steel exhaust system
- Expansion tank (coolant)
- Engine suspension frame
- Integrated AC generator with external rectifier-regulator (12 V 20 A DC)
- Propeller drive thru integrated gearbox with shock absorber and overload clutch (optional on configuration UL2)
- Oil tank
- External start relay
- Drive of hydraulic governor (on configuration 3 only)

## 7.1.2) Auxiliary equipment (optional)

Any equipment not included as part of the standard engine version and thus not a fixed component of the engine is not in the volume of supply.

Components especially developed and tested for this engine are readily available at BRP-Rotax.

### Auxiliary equipment certified

The following auxiliary equipment has been developed and tested for this engine.

- external alternator
- vacuum pump (feasible on configuration 2 only)
- drive for tachometer/hour-meter
- oil radiator with connections
- coolant radiator
- coolant overflow bottle

#### **⚠ WARNING**

**Non-compliance can result in serious injuries or death!**  
The user assumes all risks possibly arising by utilizing auxiliary equipment. The furnishing of proof in accordance to the latest FAR or EASA has to be conducted by the aircraft manufacturer.

### Auxiliary equipment not certified

The following auxiliary equipment has not been developed and tested for this engine.

- intake filter
- Flydat
- shock mount
- mechanical tachometer
- electric tachometer
- oil hose

### 7.1.3) Technical data

Description	914 F/UL
Bore	79.5 mm (3.13 in)
Stroke	61 mm (2.4 in)
Displacement	1211 cm <sup>3</sup> (73.9 in <sup>3</sup> )
Compression ratio.	9.0 : 1

### 7.1.4) Engine components

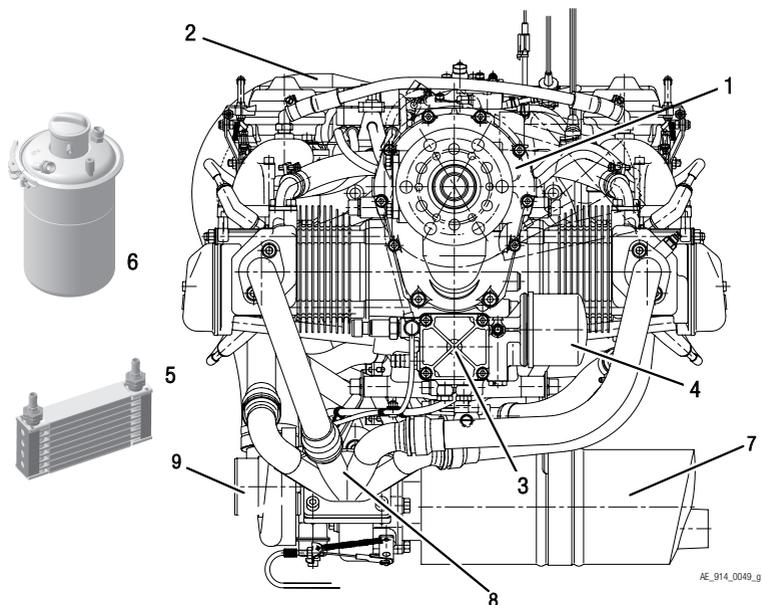

Figure 1: Engine components

- |   |                          |   |                         |
|---|--------------------------|---|-------------------------|
| 1 | <i>Propeller gearbox</i> | 2 | <i>Airbox</i>           |
| 3 | <i>Oil pump</i>          | 4 | <i>Oil filter</i>       |
| 5 | <i>Oil cooler</i>        | 6 | <i>Oil tank</i>         |
| 7 | <i>Exhaust</i>           | 8 | <i>Exhaust manifold</i> |
| 9 | <i>Turbocharger</i>      |   |                         |

## 7.1.5) Cylinder arrangement

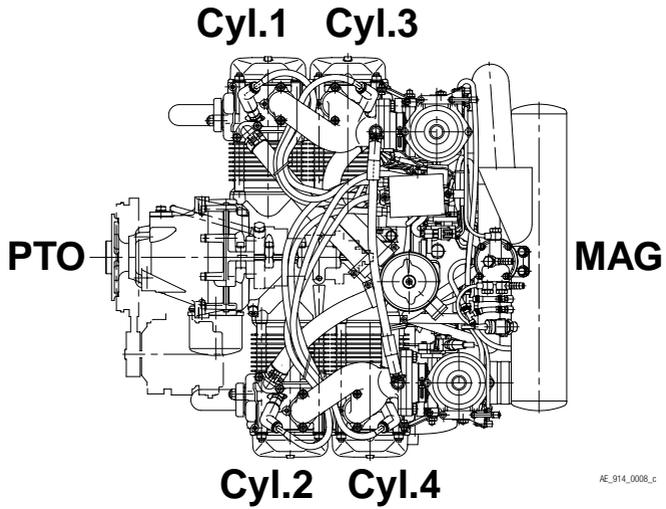

Figure 2: Cylinder arrangement

## 7.1.6) Direction of rotation

Direction of rotation on propeller shaft: counter clockwise, viewed from the front.

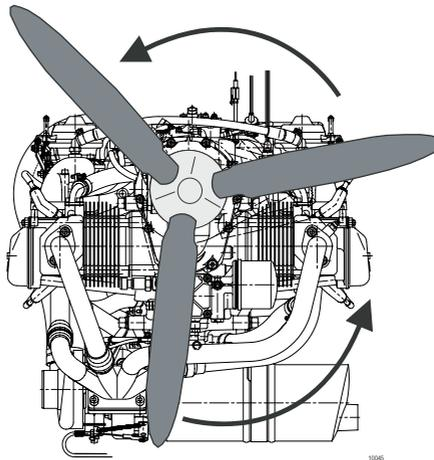

Figure 3: Normal direction of propeller rotation (engine)

## 7.2) Cooling system

### System Overview

The cooling system of the engine is designed for liquid cooling of the cylinder heads and ram-air cooling of the cylinders. The cooling system of the cylinder heads is a closed circuit with an expansion tank.

### Coolant flow

The coolant flow is forced by a water pump, driven from the camshaft, from the radiator to the cylinder heads. From the top of the cylinder heads the coolant passes on to the expansion tank. Since the standard location of the radiator is below engine level, the expansion tank located on the top of the engine allows for coolant expansion.

### Expansion tank

From the expansion tank the coolant is sucked back to the water pump. In common installations the coolant passes a radiator in between. Additionally the expansion tank is closed by a pressure cap (with excess pressure valve and return valve). At temperature rise of the coolant the excess pressure valve opens and the coolant will escape via hose at atmospheric pressure. In common installation this hose is connected to an overflow bottle. This overflow bottle allows the coolant to be sucked back into the cooling circuit as the engine is cooling down.

### Coolant temperature measuring

The coolant temperature sensor is located on cylinder head 4 (Applicable for engine S/N with Suffix-01).

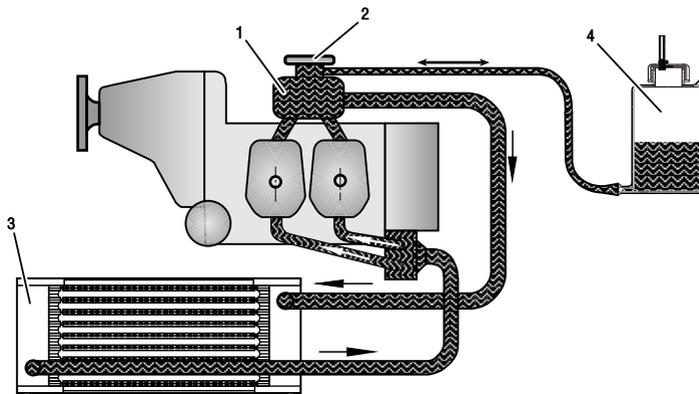

09152

Figure 4: Cooling system (symbolic)

- |   |                |   |                 |
|---|----------------|---|-----------------|
| 1 | Expansion tank | 2 | Pressure cap    |
| 3 | Radiator       | 4 | Overflow bottle |

## 7.3) Fuel system

### Fuel

The fuel flows from the tank via a filter/water trap to the two electric fuel pumps connected in series. From the pumps fuel passes on via the fuel pressure regulator to the two carburetors.

### NOTE

*Parallel to each fuel pump a separate check valve is installed.*

### Fuel pressure control

The fuel pressure regulator ensures that the fuel pressure is always maintained approx. 0.25 bar (3.63 psi) above the variable boost pressure in the "airbox".

### Return line

#### ATTENTION

**The fuel return must be a line of low flow resistance. Max. tolerated pressure loss is 0.1 bar (1.5 p.s.i.) between fuel pressure control and tank inlet with both electric fuel pumps in action. Otherwise the carburetors could flood.**

Via the return line surplus fuel flows back to the fuel tank.

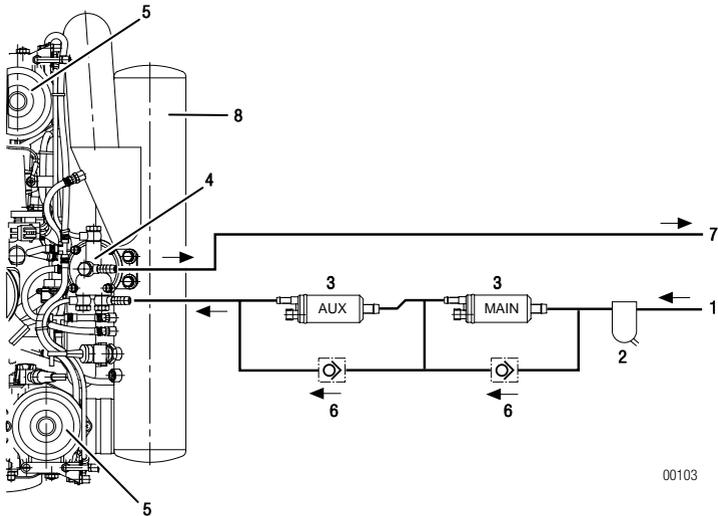

00103

1 fuel tank

2 filter/water trap

3 electric fuel pumps

4 fuel pressure regulator

---

5 carburetor

6 check valve

7 return line

8 airbox

Figure 5: Fuel system

## 7.4) Lubrication system

The engine is provided with a dry sump forced lubrication system with a main oil pump with integrated pressure regulator. The airframe manufacturer is responsible for the main layout and the component selection for the lubrication system.

### Lubrication

The main oil pump sucks the motor oil from the oil tank via oil radiator and forces it through the oil filter to the points of lubrication (lubricates also the plain bearings of the turbocharger and the propeller governor).

### NOTE

*The oil radiator is optional.*

### Crankcase

The surplus of oil emerging from the points of lubrication accumulates on the bottom of crankcase and is forced back to the oil tank by the piston blow-by gases.

### Oil pump

The oil pumps are driven by the camshaft.

### Oil circuit vented

The oil circuit is vented via bore on the oil tank.

### Oil temperature sensor

The oil temperature sensor for reading of the oil inlet temperature is located on the oil pump housing.

### Turbocharger

The turbocharger is lubricated via a separate oil line (from the main oil pump).

The oil emerging from the turbocharger collects in a stainless steel oil sump and is sucked back to the secondary oil pump and then pumps back to the main oil tank via the oil line.

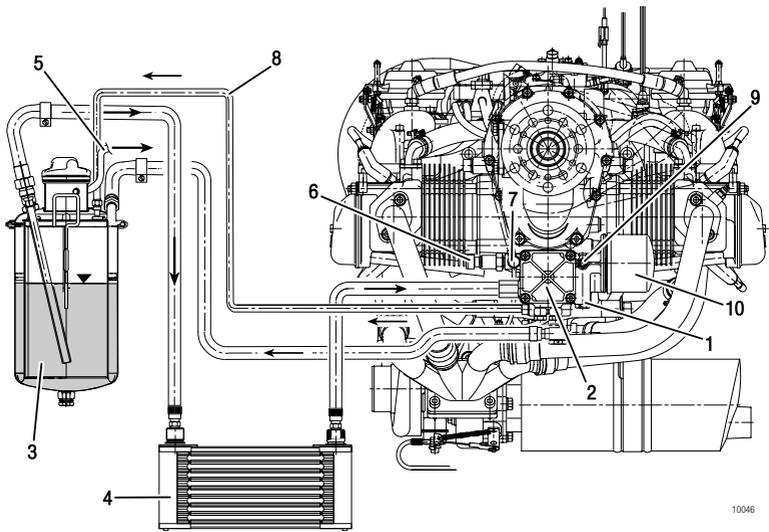

10046

Figure 6: Lubrication system

- |   |                                     |    |  |
|---|-------------------------------------|----|--|
| 1 | <i>Pressure regulator</i>           | 2  | <i>Oil pump</i>                                  |
| 3 | <i>Oil tank</i>                     | 4  | <i>Oil radiator</i>                              |
| 5 | <i>Venting tube</i>                 | 6  | <i>Oil pressure sensor</i>                       |
| 7 | <i>Oil line (main oil pump)</i>     | 8  | <i>Oil line (secondary oil pump to oil tank)</i> |
| 9 | <i>Oil temperature sensor (oil)</i> | 10 | <i>Oil filter</i>                                |

## 7.5) Electric system

The ROTAX® 914 engine is equipped with a dual ignition unit of a breakless, capacitor discharge design, with an integrated generator.

The ignition unit needs no external power supply.

### Charging coils

Two independent charging coils located on the generator stator supply one ignition circuit each. The energy is stored in capacitors of the electronic modules. At the moment of ignition 2 each of the 4 external trigger coils actuate the discharge of the capacitors via the primary circuit of the dual ignition coils.

### NOTE

*An additional trigger coil is provided for rev counter signal.*

Firing order: 1 - 4 - 2 - 3

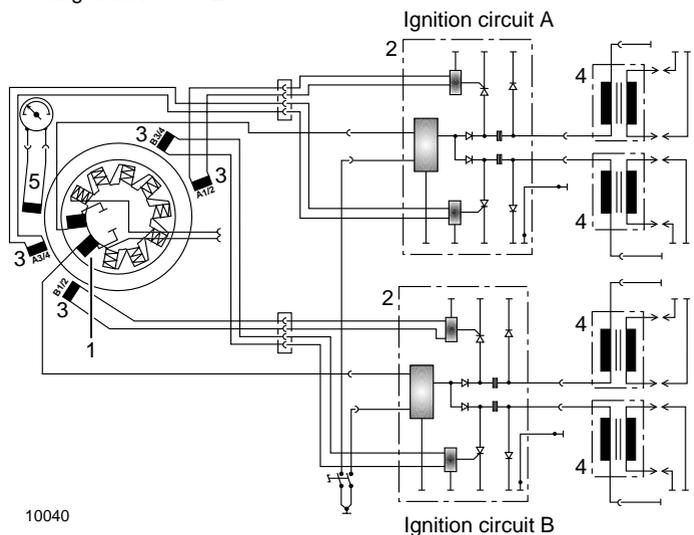

- |   |                                   |   |                     |
|---|-----------------------------------|---|---------------------|
| 1 | Charging coils                    | 2 | Electronic modules  |
| 3 | Trigger coils for ignition signal | 4 | Dual ignition coils |
| 5 | Trigger coil for speed signal     |   |                     |

Figure 7: Ignition circuit

## 7.6) Turbo charger and control system

### General

The ROTAX® 914 engine is equipped with an exhaust gas turbocharger, making use of the energy in the exhaust gas for pre-compression of the intake air (boost pressure).

### Regulation boost pressure

The boost pressure in the airbox is controlled by means of an electronically controlled flap (waste gate) in the exhaust gas turbine.

#### NOTE

*The waste gate regulates the speed of the turbo charger and consequently the boost pressure in the airbox.*

### Throttle position

The required nominal boost pressure in the airbox is determined by the throttle position sensor mounted on the carburetor 2/4. The sensor's transmitted position is linear from 0 to 115 % corresponding to a throttle position from idle to full power.

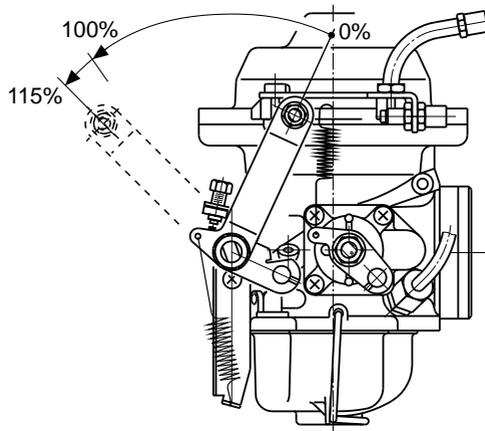

Figure 8: Throttle position

### Nominal boost pressure

For correlation between throttle position and nominal boost pressure in the airbox, refer to the diagram.

#### ATTENTION

As shown in the diagram, the throttle position at 108 to 110 % results in a rapid rise of nominal boost pressure. To avoid unstable boost, the throttle should be moved smoothly through this area either to full power (115 %) or, on a power reduction, to max. continuous power (100 %).

In this range (108 to 110 % throttle position) small changes in throttle position have a big effect on engine performance and

speed, but are virtually not apparent for the pilot from the throttle lever position.

<b>ATTENTION</b>
<p><b>Possible control fluctuations (surging).</b>                  The exact setting for a specific performance is virtually impossible in this range and has to be prevented.</p>

**Throttle position versus nominal airbox pressure**

**NOTE**

*In the course of model refinement some parameters have been slightly changed. Diagram and table shown the current state of software.*

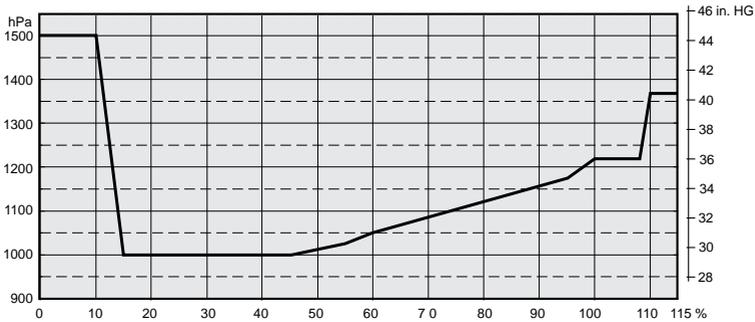

Figure 9: Throttle position versus nominal airbox pressure

The most important points for engine operation:

engine performance	throttle position	nominal airbox pressure
Idling of engine	~0 %	1500 hPa (44.3 in.HG)
max. continuous performance	100 - 108 %	1220 hPa (36.0 in.HG)
take-off performance	110 - 115 %	1370 hPa (40.5 in.HG)

**Nominal pressure**

Besides the throttle position, overspeeding of the engine and too high intake air temperature have an effect on the nominal boost pressure. If one of the stated factors exceeds the specified limits, the boost pressure is automatically reduced, thus protecting the engine against overload.

## 7.6.1) TCU caution lamps

### Caution lamp

The TCU (Turbo Control Unit) is furnished additionally with output connections for an external “red” boost lamp and an “orange” caution lamp for indication of function of the TCU.

### Function test

#### **⚠ WARNING**

##### **Non-compliance can result in serious injuries or death!**

The engine must not be taken into operation before having corrected the cause of deficiency.

When switching on the voltage supply, the two lamps are automatically subject to a function test. Both lamps illuminate for 1-2 seconds, then they extinguish. If they do not, a check as per Maintenance Manual is necessary.

### Orange caution lamp

If the caution lamp illuminates during the function test and then goes off this indicates the TCU is ready for operation. If the lamp is blinking, this indicates a malfunction of the TCU or its periphery.

[See Chapter 4\) Abnormal operation.](#)

### Red boost lamp

#### **ATTENTION**

##### **Engine could be thermally and mechanically overstressed.**

The red boost lamp helps the pilot to avoid full power operation for longer than 5 minutes.

- Exceeding of the admissible boost pressure will activate the red boost lamp, being continuously illuminated.  
[See Chapter 4\) Abnormal operation.](#)
- The TCU registers the time of full throttle operation (boost pressure). Full throttle operation for longer than 5 minutes will make the red boost lamp blink.  
[See Chapter 4\) Abnormal operation.](#)

## 7.7) Exhaust system

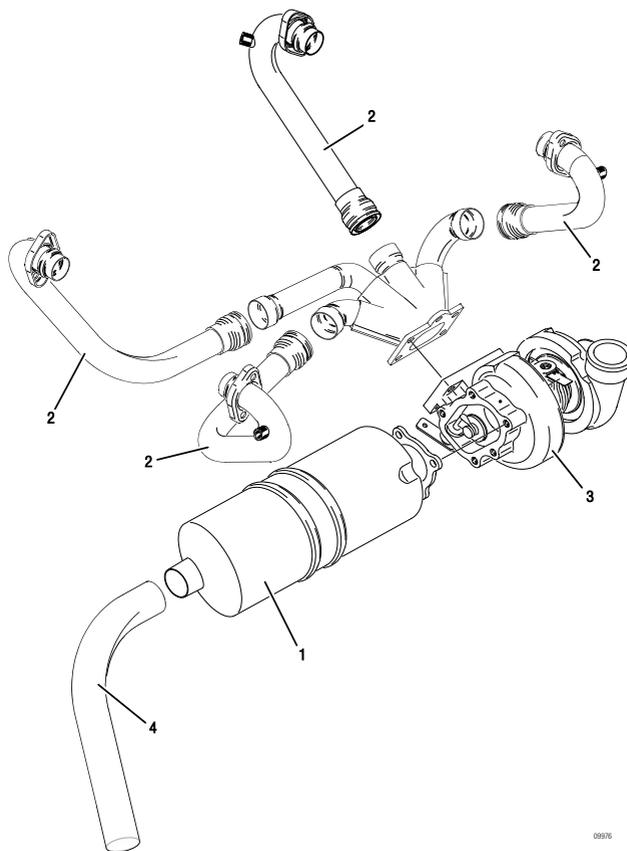

Figure 10: Turbocharger/Exhaust system

- |   |              |   |               |
|---|--------------|---|---------------|
| 1 | Muffler      | 2 | Exhaust pipes |
| 3 | Turbocharger | 4 | Exhaust below |

### Exhaust flow

The Exhaust gases are pushed out of the cylinders through the exhaust pipes and are brought together in the exhaust manifold. From there the exhaust gases pass the turbine side of the turbocharger (depending on the waste gate position). From there the exhaust gases leave the engine through the muffler.

### Exhaust Gas Temperature Sensors (EGT)

The sensors for reading the exhaust gas temperature are located on the exhaust pipes near the cylinder outlet.

## 7.8) Propeller gearbox

**Reduction ratio** For the engine type 914 one reduction ratio is available..

Reduction ratio	914 F/UL
crankshaft: propeller shaft	2.43:1

**Overload clutch** Depending on engine type, certification and configuration the propeller gearbox is supplied with or without an overload clutch.

### NOTE

*This overload clutch will prevent any undue load to the crankshaft in case of ground contact of the propeller.*

### NOTE

*The overload clutch is installed on serial production on all certified aircraft engines and on the non-certified aircraft engines of configuration 3.*

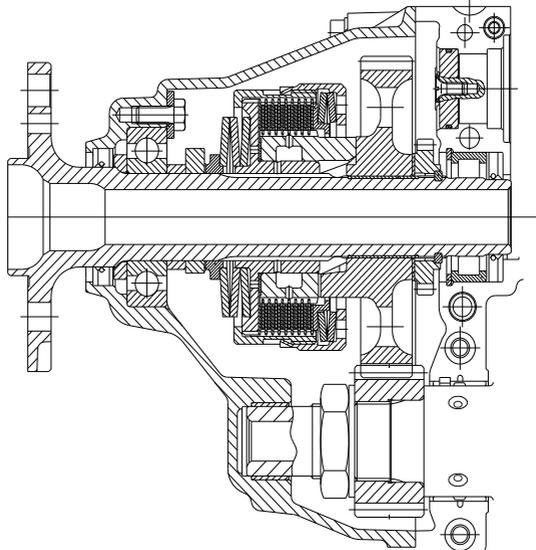

Figure 11: Overload clutch

Fig. shows a propeller gearbox of configuration 2 with the integrated overload clutch.

**Torsional shock absorber**

The design incorporates a torsional shock absorber. The shock absorbing is based on progressive torsional cushioning due to axial spring load acting on a dog hub.

**Backlash**

On the gearbox version with overload clutch the design incorporates a friction damped free play at the dogs to warrant proper engine idling. Due to this backlash at the dogs a distinct torsional impact arises at start, stop and at sudden load changes, but due to the built-in overload clutch it will remain harmless.

**NOTE**

*This overload clutch will also prevent any undue load to the crankshaft in case of ground contact of the propeller.*

See Service Letter SL-914-013

**Vacuum pump or hydraulic governor**

Only at configuration 3.

Alternatively either a vacuum pump or a hydraulic governor for constant speed propeller can be used. The drive is in each case via the propeller reduction gear.

<b>gear ratio</b>	
crankshaft: propeller shaft	2.43:1
propeller shaft: hydraulic governor/ vacuum pump	0.758:1
crankshaft: hydraulic governor/ vacuum pump	1.842:1

**NOTE**

*Transmission ratio between crankshaft and hydraulic governor or vacuum pump is 1.842 i.e. the speed of the hydraulic governor or vacuum pump is 0.54 of engine speed.*

## 8) Preservation and storage

### Topics in this chapter

8.1 Engine preservation and storage .....	2
8.2 Engine back to operation .....	3

#### Safety

All checks to be carried out as specified in the current Maintenance Manual Line (last revision).



As well as the maintenance and special checks, see Maintenance Manual Line for the engine type 914.

#### **⚠ WARNING**

##### **Non-compliance can result in serious injuries or death!**

Only qualified staff (authorized by the Aviation Authorities) trained on this particular engine, is allowed to carry out maintenance and repair work.

#### **NOTE**

*Other useful information for service and airworthiness of your engine you'll find on*

[www.rotax-owner.com](http://www.rotax-owner.com).

#### **ATTENTION**

**Carry out all directives of Service Bulletins (SB), according to their priority. Observe applicable Service Instructions (SI) and Service Letter (SL).**

## 8.1) Engine preservation and storage

**⚠ WARNING**

**Risk of burnings and scalds! Hot engine parts!**  
Conduct checks on the cold engine only!

Due to the special material of the cylinder wall, there is no need for extra protection against corrosion for ROTAX® aircraft engines. At extreme climatic conditions and for long out of service periods we recommend the following to protect the valve guides against corrosion:

Step	Procedure
1	Operate the engine until the temperatures have stabilized for a period of 5 min (engine oil temperature between 50 to 70 °C (122 to 160 °F)).
2	Shut-off engine.
3	Allow the engine to cool down.
4	Change oil.
5	Remove the top spark plugs and spray into openings with corrosion inhibiting oil.
6	Turn the propeller several times by hand in direction of the engine rotation, so that the corrosion inhibiting oil reaches all necessary points.
7	Install the spark plugs in accordance to the Maintenance Manual.
8	Close <b>all</b> openings on the cold engine, such as exhaust end pipe, venting tube, air filter etc. against entry of dirt and humidity.
9	Spray all steel external engine parts with corrosion inhibiting oil. Drain carburetor float chambers.

## 8.2) Engine back to operation

If preservation (including oil change) took place within a year of storage, oil renewal will not be necessary. For longer storage periods repeat preservation annually.

Step	Procedure
1	Remove all plugs and caps.
2	Clean spark plugs with plastic brush and solvent.
3	Reinstall.

**INTENTIONALLY LEFT  
BLANK**

## 9) Supplement

### Topics in this chapter

9.1 Form .....	2
----------------	---

See [Form](#).

According to the regulation of EASA part 21.A.3 the manufacturer shall evaluate field information and report to the authority. In case of any relevant occurrences that may involve malfunction of the engine, the form on the next page should be filled out and sent to the responsible ROTAX® authorized aircraft engines distributor or their independent Service Center.

#### **NOTE**

*The form is also available from the official ROTAX® AIRCRAFT ENGINES Website in electronic version.*

#### **Authorized Distributor**

Overview of ROTAX® authorized aircraft engines distributor or their independent Service Center.

Refer to the official ROTAX® AIRCRAFT ENGINES Website [www.FLYROTAX.com](http://www.FLYROTAX.com).

## 9.1) Form

Customer Service Information Report		ROTAX <sup>®</sup> AIRCRAFT ENGINES	
<b>When / Where / What</b>			
Accident / Incident Date:		State:	
Location Of Occurrence:			
Headline:			
Narrative:			
<b>Aircraft identification</b>			
Aircraft registration:		Aircraft category:	
Manufacturer:		Model / Series:	
Serial number:		Aircraft total time:	
<b>Flight details</b>			
Flight phase:		Operator:	
Last departure point:		Planned destination:	
<b>Engine information</b>			
Type:		Serial number:	
Time since new [h]:		Time since overhaul [h]:	
Date overhaul:		Date inspection / maintenance:	
<b>Propeller information</b>			
Manufacturer:		Model / Series:	
Serial number:		Propeller position:	

Figure 1: Form

## 10) Proper disposal

### **ENVIRONMENTAL NOTE**

**Please observe the disposal regulations applicable in your area.**

#### **General**

All old/used parts, liquids and chemical agents be disposed of according to local ordinance regulations.

#### **Packaging**

The disposal of the packaging is the customer's responsibility and has to take place in accordance with the current regulations of the country in which it has been removed.

#### **Liquids**

- **Engine oil:**  
Dispose of engine oil at the respective oil collecting point or hand it over to an approved disposal company
- **Coolant:**  
Dispose of coolant at the respective collecting point or hand it over to an approved disposal company
- **Fuel:**  
Dispose of fuel at the respective collecting point or hand it over to an approved disposal company

### **⚠ WARNING**

Flammable material must be placed at a sufficient distance from all sources of ignition, direct and strong sunlight, spotlights and heating devices, so that it cannot be ignited by such items.

### **ENVIRONMENTAL NOTE**

**Observe the safety instructions of the manufacturer of hazardous substances (coolant, oil) or fuels and the applicable regional waste disposal regulations.**

### **ENVIRONMENTAL NOTE**

**Work with the utmost care to ensure that no water pollutants can penetrate into the soil, water or the sewerage system.**

**Old/used parts**

Please return old/used parts (not periodic maintenance parts) from ROTAX® aircraft engines F.O.B to ROTAX® Authorized Distributors or their independent Service Centers.

**Chemical agents  
(cleaner, LOCTITE  
etc.)**

Please observe the safety and disposal instructions of the manufacturer.

# Index

## A

Abbreviations .....	3
Abnormal operation.....	1
After engine start .....	8
Auxiliary equipment.....	3

## B

Basic specification .....	2
Before engine start.....	5

## C

Caution lamps .....	5
Cold weather operation .....	11
Cooling system .....	6
Cruising .....	11
Cylinder arrangement.....	5

## D

Daily checks .....	2
Direction of rotation .....	5
disposal .....	1

## E

Electric system .....	10
Engine back to operation .....	3
Engine components .....	4
Engine preservation and storage.....	2
Engine shut-off .....	11
Engine start.....	5–6
Exceeding cylinder head temperature .....	7
Exceeding engine speed .....	7
Exceeding of max. admissible coolant temperature .....	7
Exceeding of max. admissible cooling system temperature .....	7

Exceeding oil temperature .....	8
---------------------------------	---

## F

Failure voltage supply TCU.....	6
Fire, Engine, compartment .....	9
Form .....	2
Fuel consumption .....	6

## G

General .....	2
General specification.....	2

## L

List of effective pages.....	1
Lubrication system .....	8

## O

Oil pressure.....	9
Oil pressure below minimum .....	8
Oil pressure below minimum - on ground .....	8
Operating limits.....	2
Operating media-Coolant .....	7
Operating media-Fuel .....	8
Operating media-Lubricants.....	9
Orange lamp .....	6

## P

Performance data .....	2
Periodical rise and drop, boost pressure, speed .....	4
Pre-flight checks .....	5
Propeller gearbox .....	15

## R

Re-Start during flight .....	7
Red boost lamp .....	5
Red boost lamp blinking .....	5

## S

Safety notice .....	7, 9
Start.....	10
Start, as per RTCA DO 178 B .....	10
Start, standard.....	10
Sudden drop, boost pressure, speed .....	3
Sudden rise, boost pressure, speed .....	3

## T

Table of amendments.....	1
Take-off.....	10
TCU, Caution lamps.....	13
Technical data .....	4
Technical documentation .....	12
Terms .....	3
Trouble shooting .....	9
Turbo charger, control system .....	11
Turbocharger/Exhaust system .....	14
Type description .....	14

## W

Weight, Accessories.....	1
Weight, Engine .....	1



**ROTAX®**



ORIGINAL TRUST  
**ROTAX  
GENUINE  
PARTS**  
ORIGINAL QUALITY  
ORIGINAL VALUE

**DON'T SETTLE  
FOR LESS.**



**IN A WORLD  
FULL OF FAKES,  
STAY ORIGINAL.**

## GENUINE PARTS

### **ORIGINAL QUALITY. ORIGINAL VALUE. ORIGINAL TRUST.**

The high levels of safety, reliability, and performance you decided on when choosing your aircraft engine are also reflected in every single part they are built of. Find your extra peace of mind by using only Rotax Genuine Parts when your engine is serviced.

Rotax Genuine Parts are manufactured to strict quality standards for an exact fit and precise operation. They ensure that your aircraft will continue to perform at maximum levels with minimum downtime and a long service life.

Rotax Genuine Parts meet Design/Production Organisation Approval (DOA/POA) and quality standards (EASA/ASTM).

All Rotax Genuine Parts come with a coverage for the first 24 consecutive months or the first 100 hours of operation, whichever occurs first.

**There is no Rotax warranty on non-genuine parts.  
If a non-genuine part causes an event on a Rotax engine,  
it may nullify any warranty.**

\* applies to all Rotax engine series except Rotax 582 UL

\*\* This offer only applies if allowed under the applicable law. Some jurisdictions may not allow, or may limit, the validity of some or part of the offer; therefore conditions may vary or not be available in some locations. For more details ask your local distributor.

# ROTAX®



---

Engine serial no.

---

Type of aircraft

---

Aircraft registration no.

Rotax® authorized distributor



**FLYROTAX.COM**

® and TM are Trademarks of BRP-Rotax GmbH & Co KG.  
© 2019 BRP-Rotax GmbH & Co KG. All rights reserved.

